

# INSTALLATION INSTRUCTIONS



## Magnum Force Elite Stage-2 Intake: 51/54-11662-B 50-11662-B/BV/C/CV '08-'13 BMW M3 (E90/92/93) V8-4.0L

Read these instructions carefully before proceeding to install system. Verify the components below with the actual contents. Ensure you have the tools and expertise required to install this system. If you have any questions, contact aFe at (951)493-7100 and ask for "tech support".

### APPLICATION:

Make: BMW  
Model: M3 (E90/92/93)  
Year: 2008 - 2013  
Engine: V8-4.0L (S65)

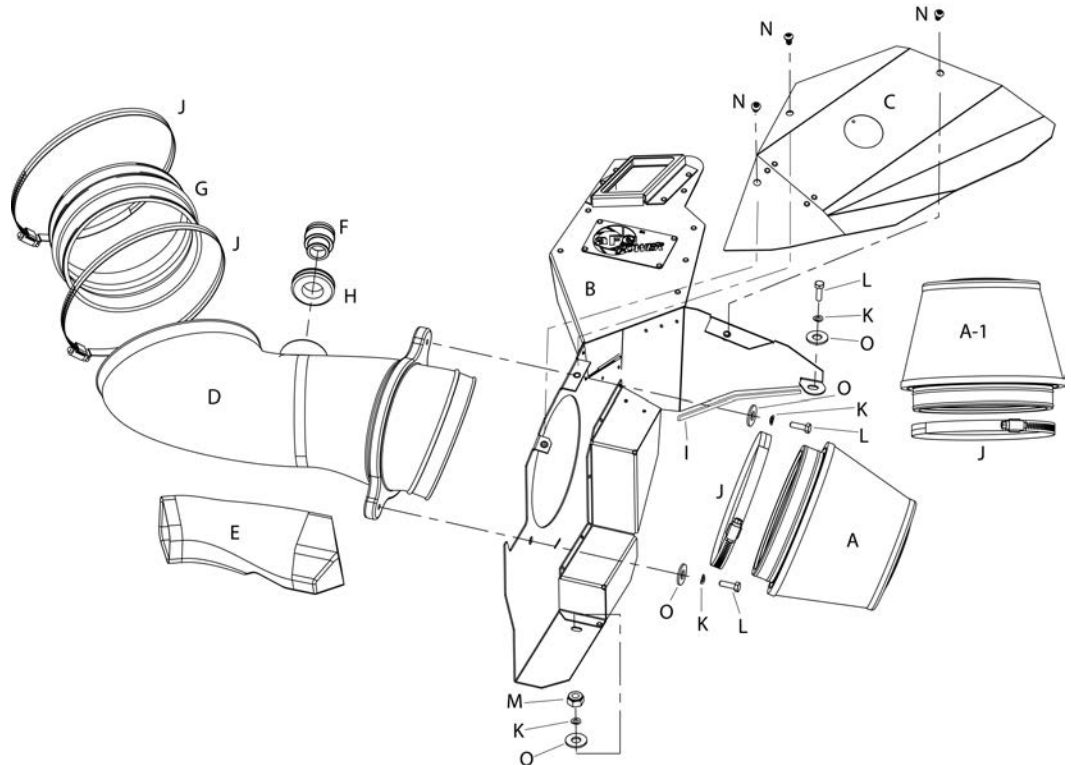

### Required Tools:

- 2.5 mm allen wrench
- 10mm socket
- Flat blade screwdriver
- 5/16" Nut Driver
- Ratchet
- 1/4" Socket or 8mm nut driver
- T20 torx bit

### NOTES:

- Legal in California for use only on race vehicles that will not be used on public streets and highways.
- Failure to follow installation instructions and not using the provided hardware may damage the system.
- Retain your stock intake system in the event you wish to return the vehicle to stock status.
- Go to [www.afepower.com/cleaning](http://www.afepower.com/cleaning) for detailed cleaning instructions of the filter.

### PARTS LIST:

Description	Qty	50-11662-C/CV	50-11662-B/BV
		Clearcoat Part #	Black Satin Part #
A Air Filter ( <i>Pro-SR</i> ™ or	1	24-60505	24-60505
A-1 Spare filter <i>Pro Dry S</i> ™)	1	21-60505	21-60505
B Housing	1	05-01088	05-01059
C Cover	1	05C01088	05C01059
D Intake Tube	1	05-01099	05-01099
E Duct Tube	1	05-01067	05-01067
F Smog Pump Adapter	1	05-01096	05-01096
G Coupler, Hump	1	05-01262	05-01262
H Grommet	1	03-50139	03-50139
I Rubber Edge 1/16", 7.5"	1	05-00149	05-00149
J Clamps #104	4	03-50051	03-50051
K Wavy Washer: M6	4	03-50058	03-50058
L Screw, Hex Head: M6	3	03-50032	03-50032
M Hex Nut: M6X1	1	03-50059	03-50059
N Screw Button head Socket: M6x1x12	3	03-50102	03-50102
O Flat Washer: M6	3	03-50070	03-50070

Note: Part numbers ending with CV & BV are "Value Packages that include DAS scoops, a prefilter and cleaning kit that is not shown.



1- View of stock engine compartment.



5- Gently pull the intake tube off of the intake plenum.



2- Gently squeeze the stock smog pump and pull straight back to remove.



6- Pull up on the back of the intake and work the intake free from the engine bay.



3- Loosen the intake tube clamp from the intake tube with a 1/4" or 8mm nut driver or flat head screw driver.



7- Remove the stock rubber mounts that are located under the stock intake box and put them aside.



4- Remove the two airbox mounting bolts shown with 10mm socket or wrench.



8- install aFe's intake tube into the housing.





9- Install supplied hex screw, wavy washer and flat washer. Do not fully tighten.

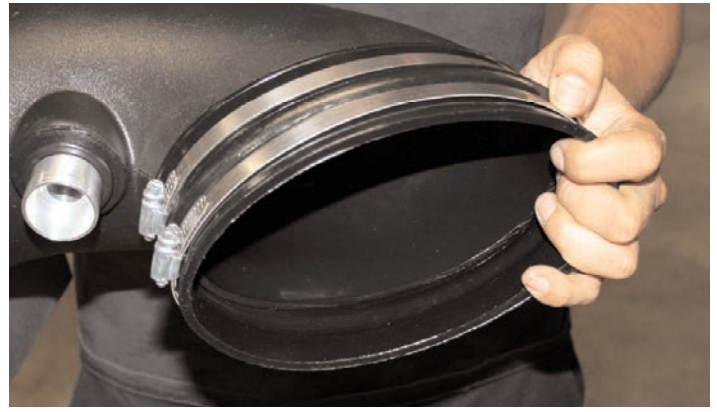

13- Position coupling onto intake tube with supplied clamps. Do not fully tighten.



10- Install supplied grommet into aFe's intake tube.



14- Carefully position housing into the vehicle and line up the mounting points.



11- Firmly press the adapter into the grommet until it is seated all the way in.



15- Line up intake tube with the intake plenum.



12- Install the supplied trim seal to the lower edge of the housing.



16- Slide the coupling onto the intake plenum, use the bead on the tube to verify that the coupling is on straight. Do not fully tighten.





17- Place the supplied nut with wavy washer onto the bottom of the housing. Do not fully tighten.



21- Once in position, push the cold air duct into the factory cold air inlet. It should fit snug to form a seal.



18- Install the supplied hex screw, wavy washer and flat washer into the upper mounting tab. Do not fully tighten



22- Tighten lower housing support nut with 10mm socket or wrench.



19- Insert the smog pump line onto the adapter and make sure it locks into place.



23- Once aligned, tighten down the upper mounting bolt with 10mm socket or wrench



20- Place the cold air duct into the housing slot, and work it into position.



24- Tighten down the bolts installed in steps #10 & #11 using a 10mm socket or wrench.





25- Tighten down both clamps on supplied coupler using a 5/16" nut driver to secure intake tube to intake manifold. Note: Do not over tighten.



29- Secure cover with supplied M6 button head screws and tighten with 2.5mm allen wrench.

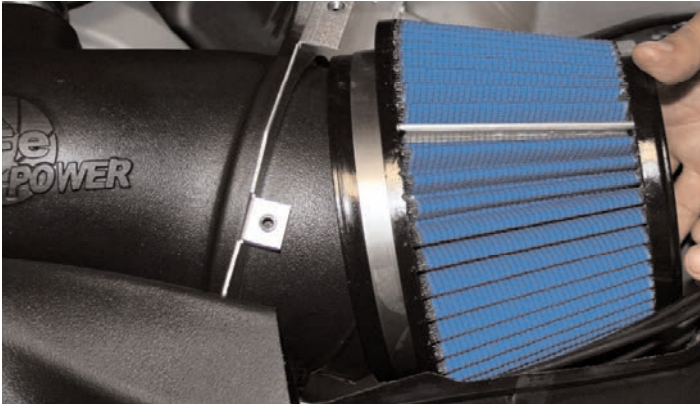

26- Slip air filter around the intake tube and position it to be facing downward. Note: Verify that filter is completely on tube. Use the tube bead for reference on positioning. Filter sits angled downward to have clearance for the cover.



30- Place enclosed CARB EO sticker on a clean/smooth surface on or near the intake system. EO identification label is required in passing the Smog Check inspection. Your Installation is now complete. Please check all components and retighten if necessary. Thank you for choosing aFe Power!

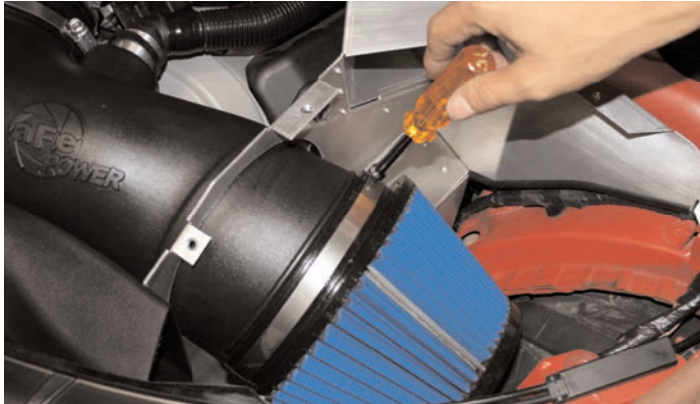

27- Once filter is in position, tighten clamp with a 5/16" nut driver. The white filter is oil-free and is included as a spare filter. The white filter is washable but should not be oiled.



28- Position cover over housing.

# PERFORMANCE DATA



## 50/51/54-11662-B 2008-2013 BMW M3 (E90/92/93) V8-4.0L (S65)

Every intake system we sell has been tested on a Mustang Chassis Dynamometer and have been proven to increase horsepower. We measure horsepower at the wheels. OE manufacturer horsepower ratings are measurement of horsepower at the engine and will be higher than that which is measured at the wheels due to power loss through the drive train.

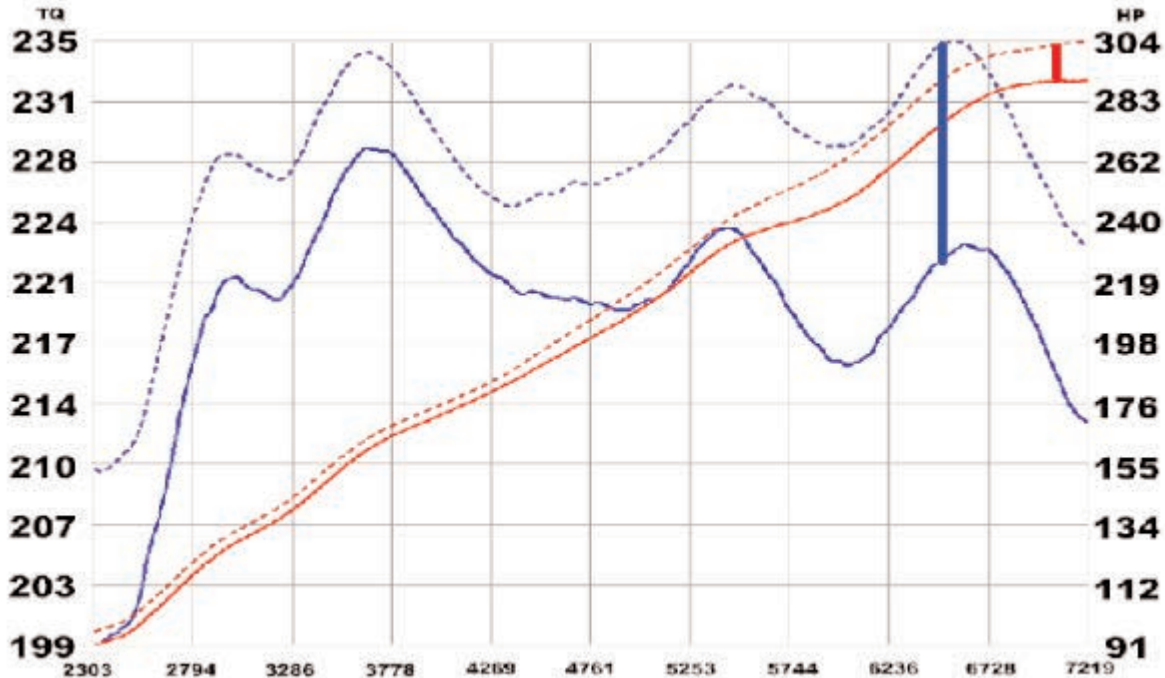

**+15 Horsepower @ 7100 RPM**  
**+13 Lbs. x FT. Torque @ 6600 RPM**

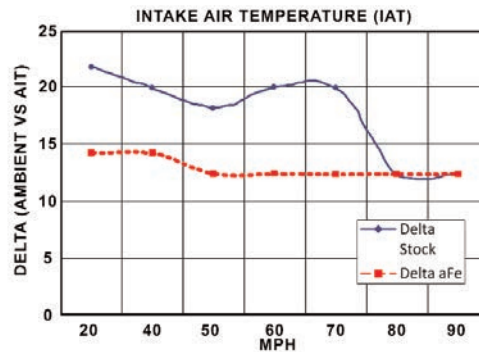
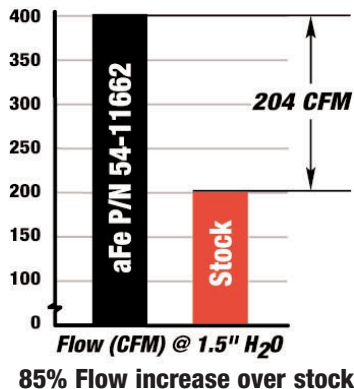

\*Test run with completely stock car with aFe intake

### aFe Air Intake System Warranty Policy

aFe offers a limited lifetime warranty on this intake system that lasts the life of the vehicle. This warranty applies only to the original purchaser of product and is non-transferrable. Proof of purchase of the aFe intake system and the vehicle are required for any warranty claims. aFe will not honor this warranty due to improper installation or fitment, damage from misuse, accidents or flying debris. This warranty is only limited to the repair and/or replacement of the aFe part. Under no circumstance will this warranty exceed the original purchase price of the aFe part nor will aFe be responsible for special, incidental or consequential damages or costs incurred due to the failure of this product. Improper use or installation, abuse, unauthorized repair or alteration will void this warranty. Warranty claims to aFe must be freight prepaid and accompanied with a dated proof of purchase. Any warranty returns must be accompanied by a valid Return Merchandise Authorization (RMA) number which can be requested from aFe Customer Service at (951)493-7100 or the return will be refused.

**advanced FLOW engineering**

252 Granite Street, Corona, CA 92879 [www.aFepower.com](http://www.aFepower.com) (951) 493-7100

06-80341  
Updated: 2/18