

advanced FLOW engineering Momentum GT Cold Air Intake System

Instruction Manual P/N: 50-70055D / 50-70055R

Make: Chevrolet Model: Silverado 2500HD/3500HD Year: 2020-2021 Engine: V8-6.6L (L8T)
Make: GMC Model: Sierra 2500HD/3500HD Year: 2020-2021 Engine: V8-6.6L (L8T)



- Please read the entire instruction manual before proceeding.
- Ensure all components listed are present.
- For technical support please call 951-493-7185.
- Ensure you have all necessary tools before proceeding.
- Do not attempt to work on your vehicle when the engine is hot.
- Retain factory parts for future use.

Label	Qty.	Description	Part Number
A1	1	Air Filter (Pro 5R)	24-91147
A2	1	Air Filter (Pro DRY S)	21-91147
B	1	Tube	05-5070055B1
C	1	Housing	05-5070055B2
D	1	Coupling, Silicone Bellows	05-01536
E	2	Clamp, T-bolt (3-13/16" - 4-1/8")	03-50265
F	1	Fitting, Vent Tube	05-01339
G	1	Fixing Clamp, 3/4"ID	03-50234
H	1	Clamp, T-bolt (8-5/16" - 8-5/8")	03-50267
I	1	Plug, Silicone	05-01429
J	2	Screw, Torx: M4x10mm	03-50490
K	2	Screw, Hex Hd: M6x1x20mm	03-50057
L	2	Washer, Flat: M6	03-50070

Installation will require the following tools:

Panel clip remover, T20 Torx driver, 8mm & 10mm nut drivers, 10mm & 20mm wrenches, 10mm & 11mm deep socket and driver

Emissions Disclaimer: This product is not currently CARB exempt and is not available for purchase in California or for use on any vehicle registered with the California Department of Motor Vehicles.

Warranty Information available at <https://afepower.com/contact#warranty>

IMPORTANT: The Air Filter Life System needs to be reset to 100% and then disabled. Follow your owner’s manual procedure titled “How to Reset the Engine Air Filter Life System” then disable the system entirely. Failure to disable the system may prompt a persisting “Check Engine Air Filter System” message.

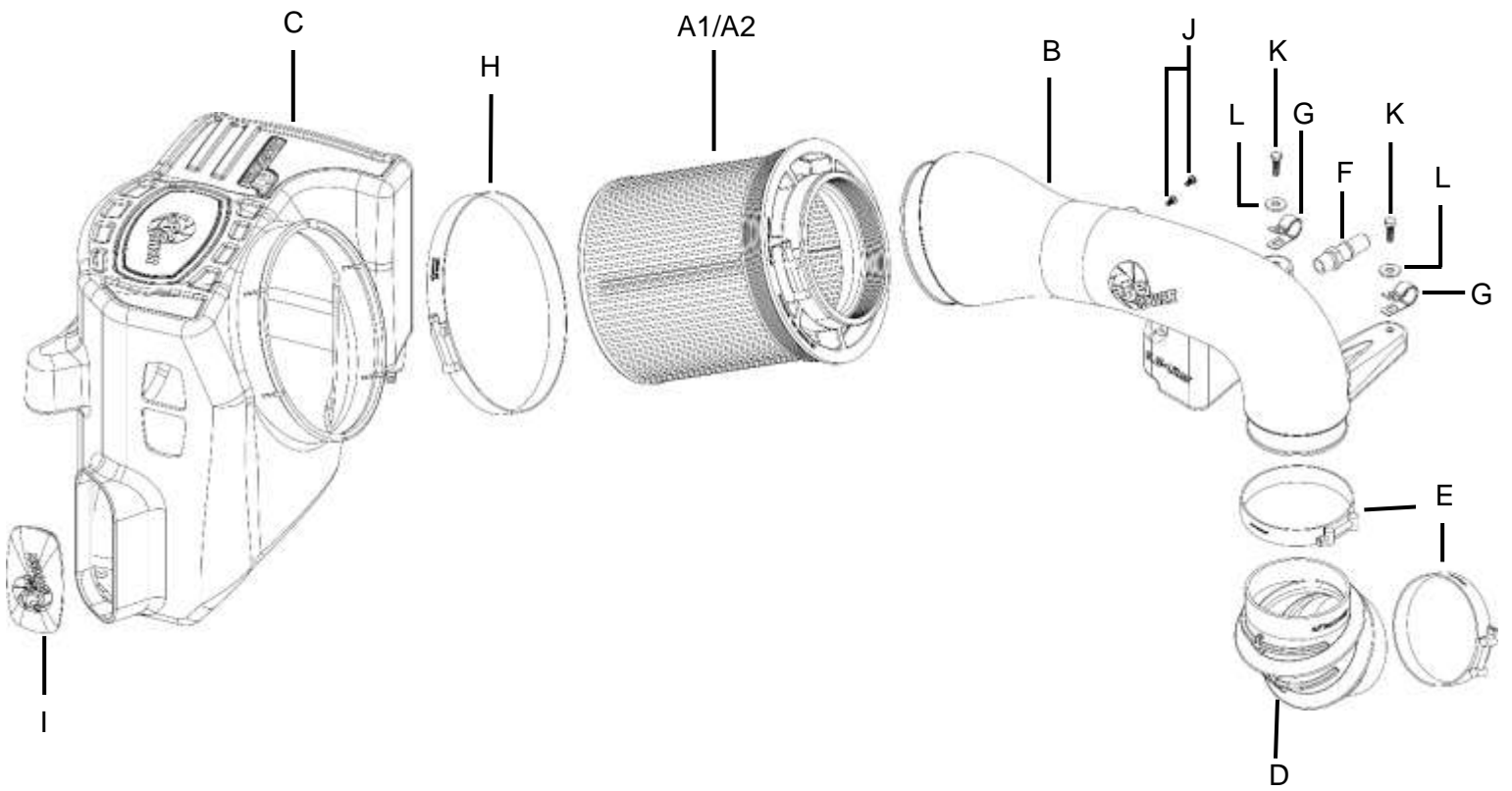
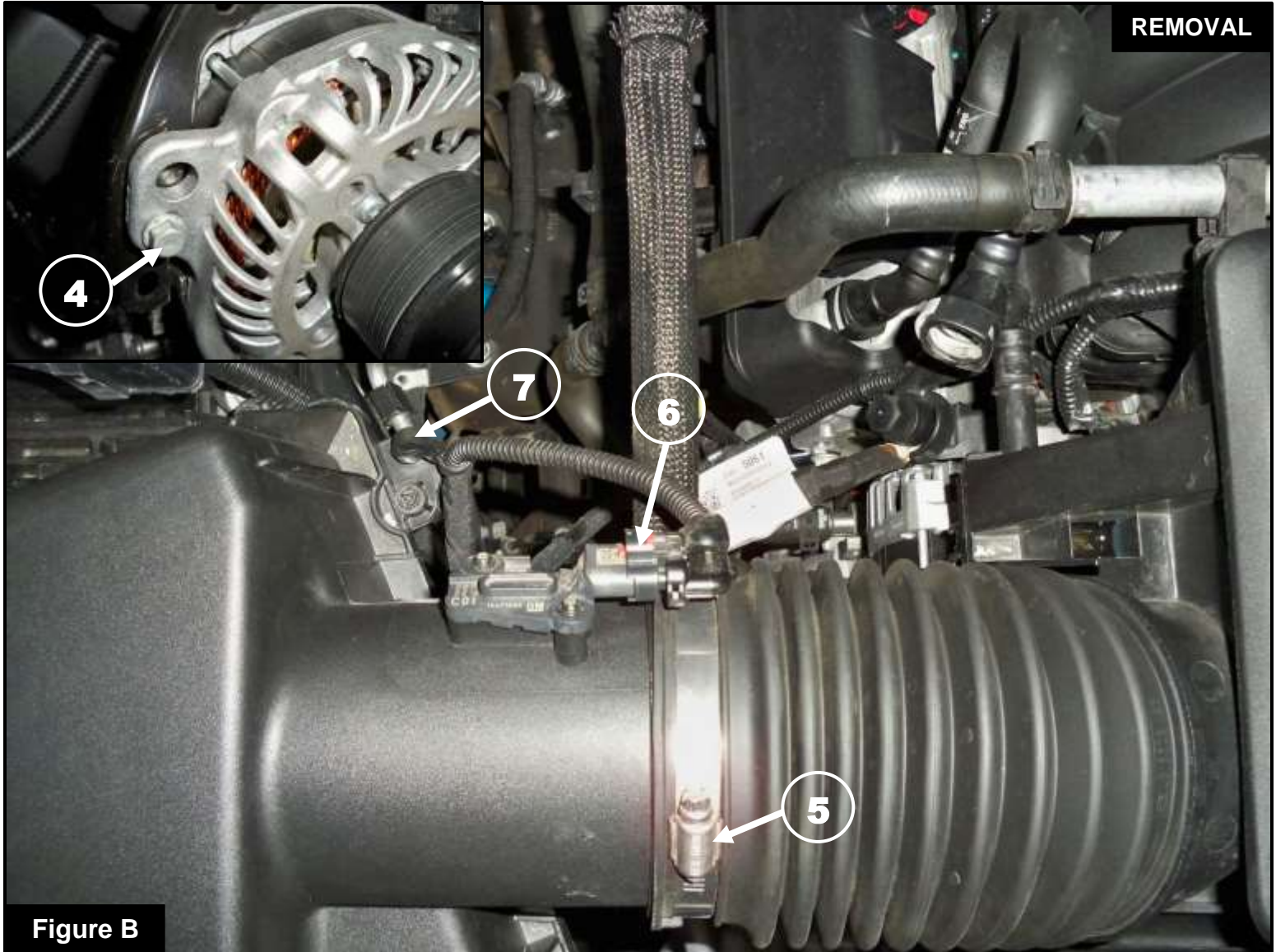



Figure A

Refer to Figure A for Steps 1-3

- Step 1: Using a panel clip remover, remove the retaining plastic clips ① holding the coolant line on top of the factory intake tube assembly.
- Step 2: Disconnect the crankcase breather hose ②.
- Step 3: Using an 8mm nut driver, loosen the hose clamp ③ at the throttle body.



Refer to Figure B for Steps 4-7

Step 4: Using a 10mm socket and driver, remove the screw (4) attaching the intake tube bracket to the alternator. Also remove any wiring harnesses if attached to the bracket.

Step 5: Using an 8mm nut driver, loosen the hose clamp (5) at the factory airbox.

Step 6: Disconnect the MAF sensor (6) and the clip (7) holding the harness.

Step 7: Remove the factory intake tube assembly and put aside.

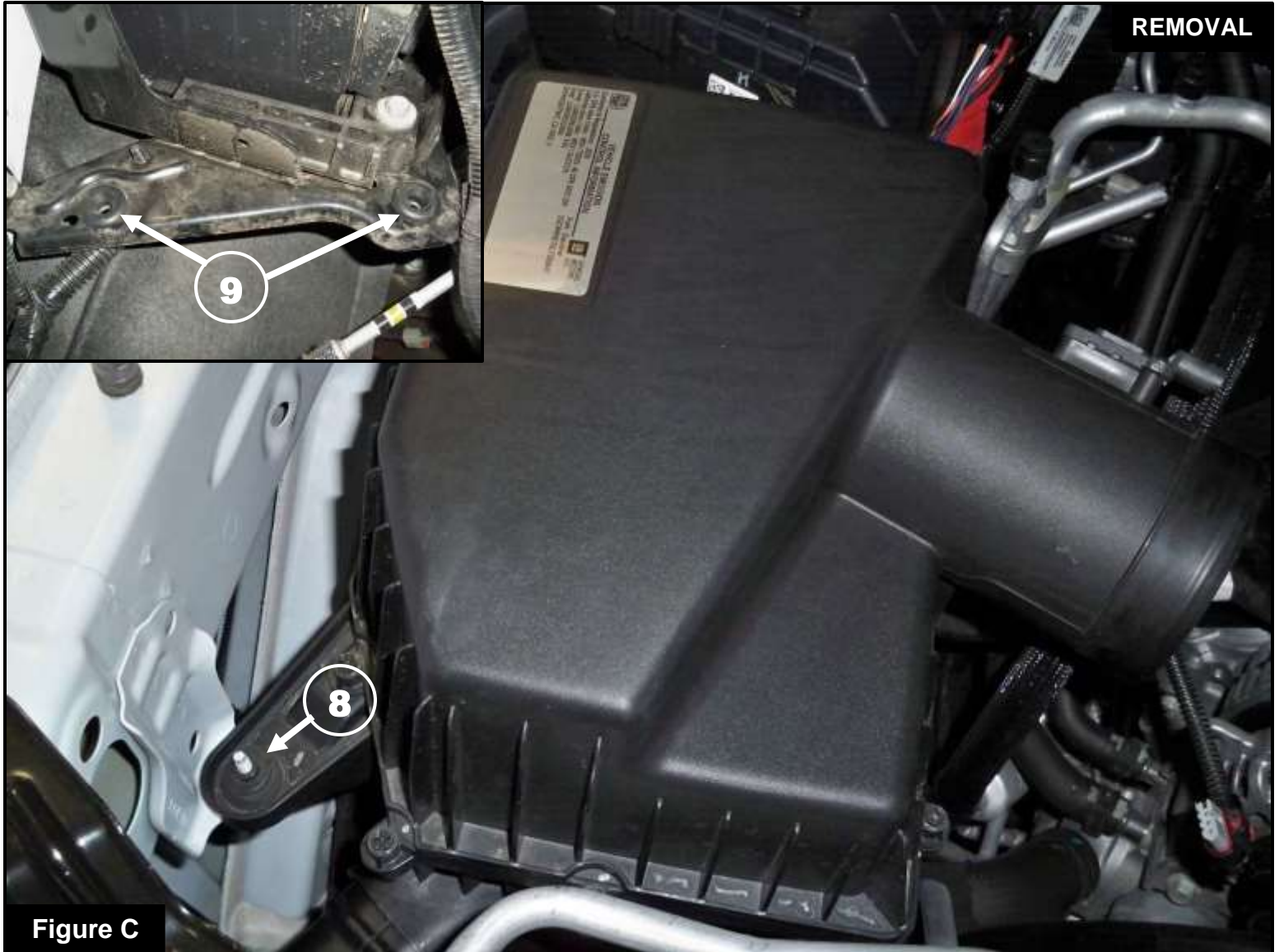

Refer to Figure C for Steps 8-9

Step 8: Using a 10mm deep socket and driver, remove the nut (8) holding the factory airbox to the fender and set the nut aside for later use.

Step 9: Remove the factory airbox by pulling it straight up from its mounting grommets. If the grommets (9) are pulled out with the factory airbox, remove them and put them back on the bracket holes.



Figure D

Refer to Figure D for Step 10

Step 10: Remove the metal insert and grommet (10) from the factory airbox and install them into the aFe POWER housing.



Refer to Figure E for Steps 11-13

Step 11: Install the aFe POWER housing on to vehicle. Make sure the mounting pins are fully seated in the mounting grommets.

Step 12: From the inside of the aFe POWER housing, use a 10mm wrench to reinstall and tighten the nut^① removed in Step 8.

Step 13: Make sure the air inlet scoop^② is inside the front opening of the aFe POWER housing.



Figure F

Refer to Figure F for Steps 14-15

Step 14: Slide the large T-Bolt clamp (10) over the air filter opening on the aFe POWER housing.

Step 15: Slide the aFe POWER filter with clamp into the housing. Do not tighten the clamps.

**Figure G****Refer to Figure G for Steps 16-17**

Step 16: Place the supplied aFe POWER coupling (14) and one of the T-Bolt clamps (15) over the throttle body. Do not tighten.

Step 17: Place the other T-Bolt clamp (16) on the installed coupling. Do not tighten.



Figure H

Refer to Figure H for Steps 18-19

Step 18: Using a T20 Torx driver, remove the MAF sensor (17) from the factory housing and install it on the aFe POWER intake tube using the supplied M4 screws.

Step 19: Using a 20mm wrench, install the supplied aluminum vent fitting (18) into the aFe POWER intake tube.

**Figure I****Refer to Figure I for Steps 20-21**

Step 20: Install the aFe POWER intake tube into the vehicle. Slide the tube into the throttle body coupling first, then into the air filter.

Step 21: Align the coupler, intake tube and clamps correctly, then using a 11mm deep socket and driver tighten all the clamps (19).



Figure J

Refer to Figure J for Steps 22-23

Step 22: Reconnect the crankcase breather hose (20).

Step 23: Reconnect the MAF sensor (21).



Figure K

Refer to Figure K for Step 24

Step 24: Use the provided plug (22) to close the additional air inlet if you want to completely seal the airbox.

Best performance gain is obtained by having more air flow (no plug).

**Figure L****Refer to Figure L for Steps 25-26**

Step 25: Secure the coolant hose to the aFe POWER intake tube with the provided fixing clamps, 6mm screws and washers⁽²³⁾. Using a 10mm nut driver, tighten the screws.

Step 26: Your installation is now complete. Thank you for choosing aFe POWER!

NOTE: Check all bolts, clamps, and connectors after 100-200 miles.



advanced FLOW engineering, inc.
252 Granite Street Corona, CA 92879
<https://afepower.com/contact>