

MOMENTUM **HD**

advanced FLOW engineering Momentum HD Cold Air Intake System

Instruction Manual P/N: 50-70056D / 50-70056T

Make: Chevrolet Model: Silverado 2500HD/3500HD Year: 2020-2021 Engine: V8-6.6L (td) L5P
Make: GMC Model: Sierra 2500HD/3500HD Year: 2020-2021 Engine: V8-6.6L (td) L5P



- Please read the entire instruction manual before proceeding.
- Ensure all components listed are present.
- For technical support please call 951-493-7185.
- Ensure you have all necessary tools before proceeding.
- Do not attempt to work on your vehicle when the engine is hot.
- Retain factory parts for future use.

Label	Qty.	Description	Part Number
A1	1	Air Filter (Pro 10R)	20-91147
A2	1	Air Filter (Pro DRY S)	21-91147
B	1	Tube	05-5070056B1
C	1	Housing	05-5070056B2
D	1	Coupling, Silicone Elbow Rdr: 100mm x 108mm 17 Deg	05-01420
E	1	Clamp, T-bolt (4-1/16" - 4-3/8")	03-50262
F	1	Clamp, T-bolt (4-5/16" - 4-5/8")	03-50499
G	1	Clamp, T-bolt (8-5/16" - 8-5/8")	03-50267
H	2	Screw, Torx: M4x8mm	03-50491
I	1	Plug, Silicone	05-01429
J	1	Seal, Inlet	05-01562

Installation will require the following tools:

T20 Torx driver, 8mm nut driver, 10mm, 11mm & 13mm deep sockets and driver, 10mm wrench

Emissions Disclaimer: This product is not currently CARB exempt and is not available for purchase in California or for use on any vehicle registered with the California Department of Motor Vehicles.

IMPORTANT: The Air Filter Life System needs to be reset to 100% and then disabled. Follow your owner’s manual procedure titled “How to Reset the Engine Air Filter Life System” then disable the system entirely. Failure to disable the system may prompt a persisting “Check Engine Air Filter System” message.

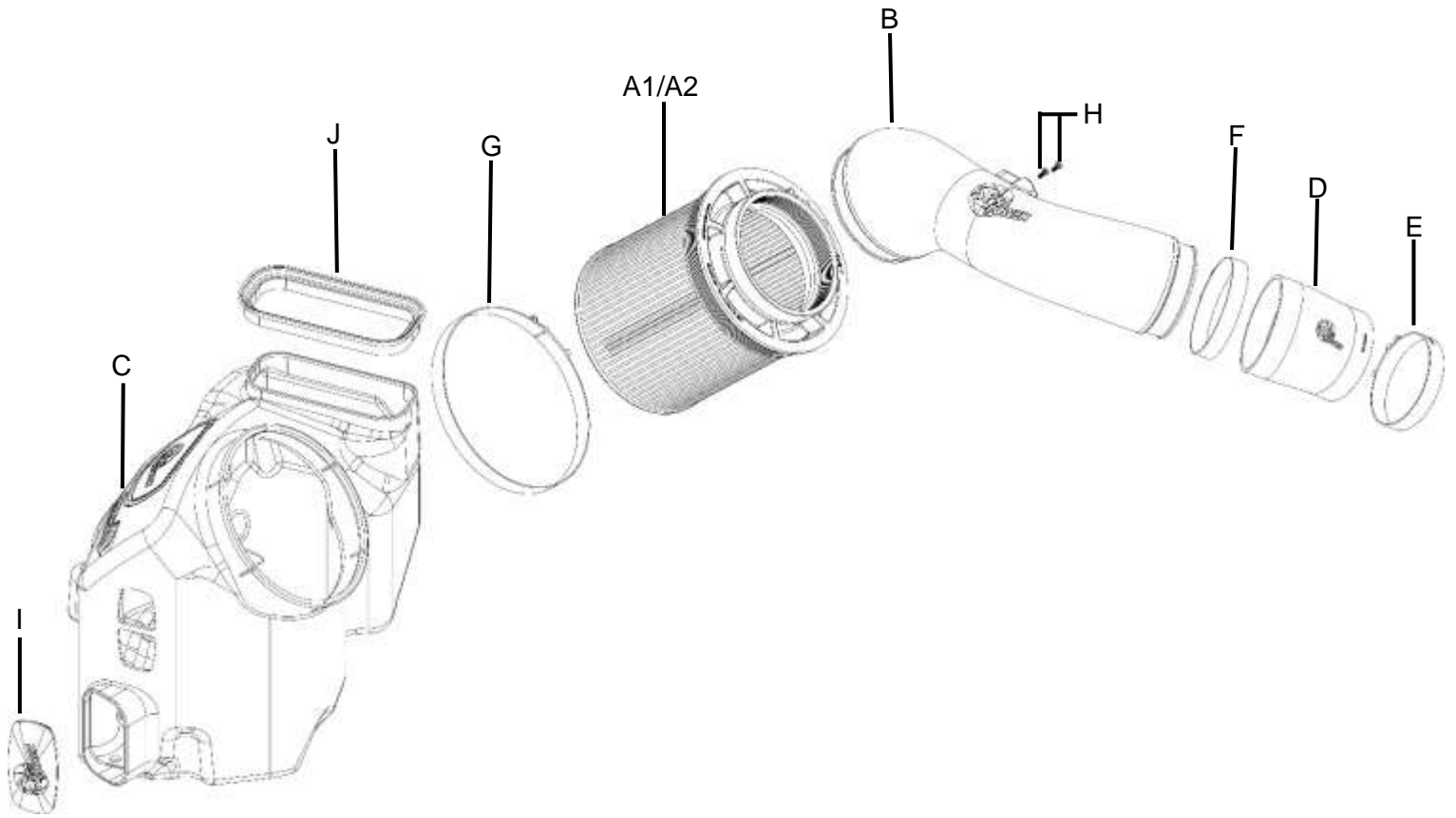
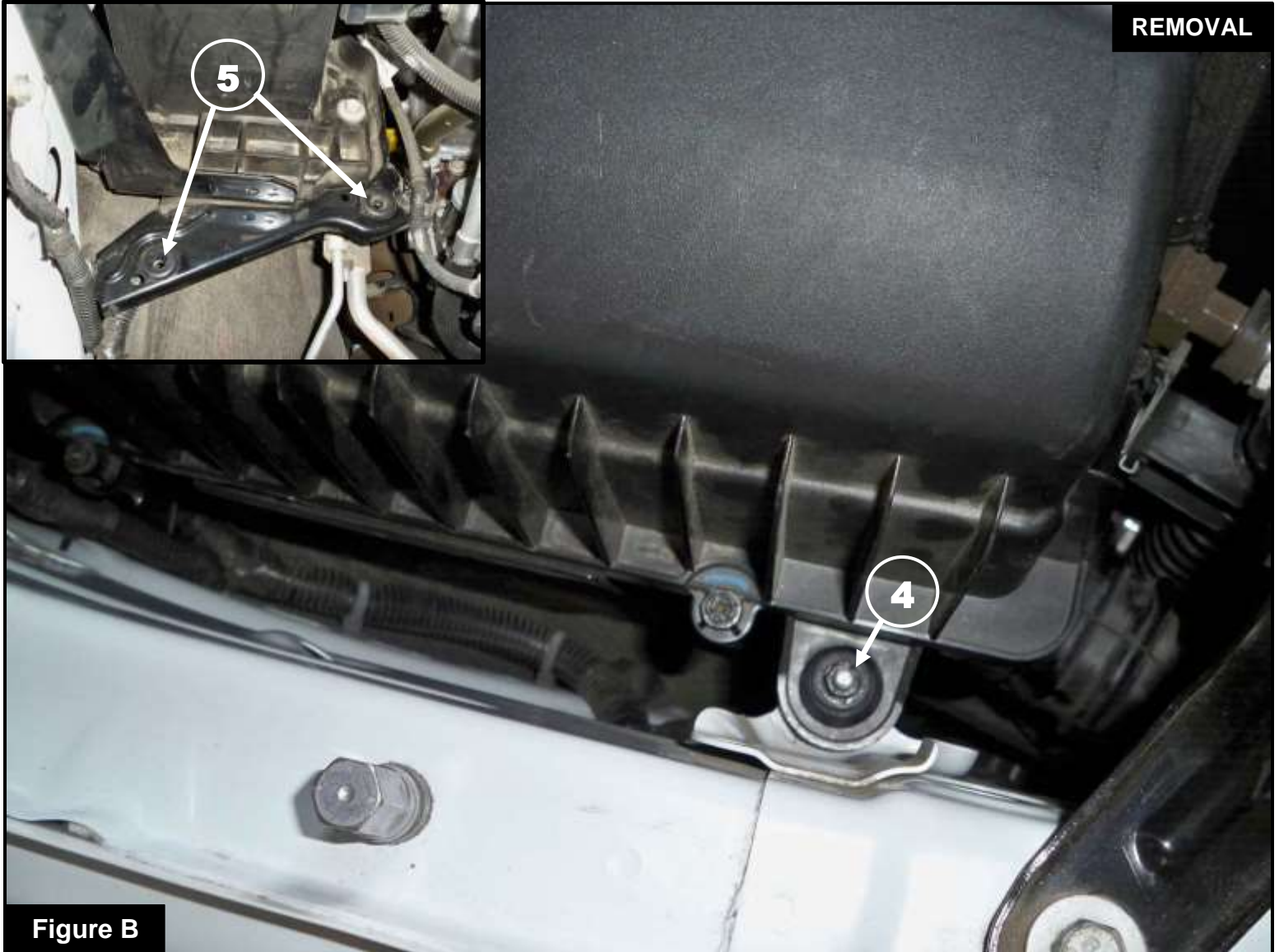

**Figure A****Refer to Figure A for Steps 1-3**

Step 1: Disconnect the MAF sensor ①.

Step 2: Using an 8mm nut driver, loosen the hose clamps ② at the factory airbox and the turbo coupling.

Step 3: Remove the factory intake tube ③.

**Figure B****Refer to Figure B for Steps 4-5**

Step 4: Using a 10mm deep socket and driver, remove the nut (4) holding the factory airbox to the fender and set the nut aside for later use.

Step 5: Remove the factory airbox by pulling it straight up from its mounting grommets. If the grommets (5) are pulled out with the factory airbox, remove them and put them back on the bracket holes.

REMOVAL



Figure C

Refer to Figure C for Step 6

Step 6: Remove the metal insert and grommet ⑥ from the factory airbox and install them into the aFe POWER housing.



Refer to Figure D for Steps 7-9

Step 7: Install the aFe POWER housing on to vehicle. Make sure the mounting pins are fully seated in the mounting grommets.

Step 8: From the inside of the aFe POWER housing, use a 10mm wrench to reinstall and tighten the nut (7) removed in Step 4.

Step 9: Make sure the air inlet scoop (8) is inside the front opening of the aFe POWER housing.

**Figure E****Refer to Figure E for Steps 10-11**

Step 10: Slide the large T-Bolt clamp ⑨ over the air filter opening on the aFe POWER housing.

Step 11: Slide the aFe POWER filter with clamp into the housing. Do not tighten the clamps.

Figure F

Refer to Figure F for Step 12

Step 12: If you wish to remove the resonator (10), loosen the clamp (11) at the turbo inlet with an 8mm nut driver. Using a 13mm deep socket, extension and driver, remove the nut (12) holding the resonator. Remove the resonator with the stock coupling.

Note: If you wish to keep the resonator skip to step 14 and reuse the factory coupling.

**Figure G****Refer to Figure G for Step 13**

Step 13: If the resonator is removed, install the supplied TB437SS clamp (13), coupling (14) and TB462SS clamp (15). Do not tighten the clamps.

**Figure H****Refer to Figure H for Step 14**

Step 14: Using a T20 Torx driver, remove the MAF sensor (16) from the factory airbox and install it on the aFe POWER intake tube using the supplied M4 screws.

**Figure I****Refer to Figure I for Steps 15-16**

Step 15: Install the aFe POWER intake tube into the vehicle. Slide the tube into the coupling first, then into the air filter.

Step 16: Align the coupling, intake tube and clamps correctly, then using a 11mm deep socket and driver tighten all the clamps ①7.

**Figure J**

Refer to Figure J for Steps 17-20

Step 17: Reconnect the MAF sensor (18).

Step 18: Install the inlet seal (19) to the top inlet of the aFe POWER housing.

Step 19: Use the provided plug (20) to close the additional air inlet if you want to completely seal the housing. Best performance gain is obtained by having more air flow (no plug).

Step 20: Check all the components are tight and secure. Your installation is now complete. Thank you for choosing aFe POWER!

NOTE: Check all bolts, clamps, and connectors after 100-200 miles.



Pro DRY S Air Filter



P/N: 21-91147

Pro 10R Air Filter



P/N: 20-91147

Pro DRY S Restore Kit



P/N: 90-59999

Blue Squeeze Restore Kit



P/N: 90-50501

Pre-Filter



P/N: 28-10273

aFe Fender Cover



P/N: 40-10230

Pro GUARD Fuel Filter



P/N: 44-FF023

Rear Differential Cover



P/N: 46-71260B

SCORCHER HD



P/N: 77-44010

SCORCHER BLUE



P/N: 77-84010

Flashlight LED USB



P/N: 40-10202

Magnetic Folding Flashlight



P/N: 40-10229

To purchase any of the items above, view airflow charts, dyno graphs, photos, and video; please go to aFepower.com.



Warranty

General Terms:

- aFe warrants their products to be free from manufacturer's defects due to workmanship and material.
- This warranty applies only to the original purchaser of the product and is non-transferrable.
- Proof of purchase of the aFe product is required for all warranty claims.
- Warranty is valid provided aFe instructions for installation and/or cleaning were properly followed.
- Proper maintenance with regular inspections of product is required to insure warranty coverage.
- Damage due to improper installation, abuse, unauthorized repair or alteration is not warranted.
- Incidental or consequential damages or cost, including installation and removal of part, incurred due to failure of aFe product is not covered under this warranty.
- All warranty is limited to the repair and/or replacement of the aFe part. To request Return Goods Authorization ("RGA"), email RGA@afepower.com or call (951)493-7100. Upon receipt of the RGA, you must return the product to the address provided in the RGA, freight prepaid and accompanied with a dated proof of purchase and the RGA. Upon receipt of the defective product and upon verification of proof of purchase, aFe will either repair or replace the defective product within a reasonable time, not to exceed thirty days.

Product Category	P/N Prefix	Warranty duration
Direct OE Replacement Filters	10, 11, 30, 31, 71, 73	Life of the vehicle
Racing Filters	18	1 year
Universal	20, 21, 23, 24, 72, TF	2 years
Air Intake Systems	50, 51, 53, 54, 55, 56, 57, 58, 75, TR, TA, TL, TM	2 years
Exhaust Systems	49	2 years
Intercoolers & Intercooler Tubes	46-2	2 years
Intake Manifolds	46-1	2 years
Differential Cover	46-7	Life of the vehicle
Exhaust Manifolds	46	2 years
Throttle Body Spacers	46-3	2 years
Turbochargers	46-6	2 years*
Fluid Filters	44	90 days
Pre-Filters	28	2 years
Heavy Duty OE Replacement	70	2 years
PowerSports OE Replacement	81, 87	2 years
PowerSports Intake Systems	85	2 years

No other warranty expressed or implied applies nor is any person or advanced FLOW engineering authorized to assume any other warranty. Some States do not allow the exclusion or limitation of incidental or consequential damages or do not allow limitations on how long an implied warranty lasts, so the above limitations or exclusions may not apply to you. This warranty gives you specific legal rights, and you may also have other rights which vary from State to State.

*See turbocharger warranty for more info



advanced FLOW engineering, inc.

252 Granite Street Corona, CA 92879
TEL: 951.493.7100 • TECH: 951.493.7134
E-Mail: Tech@aFepower.com

P/N: 06-81342