

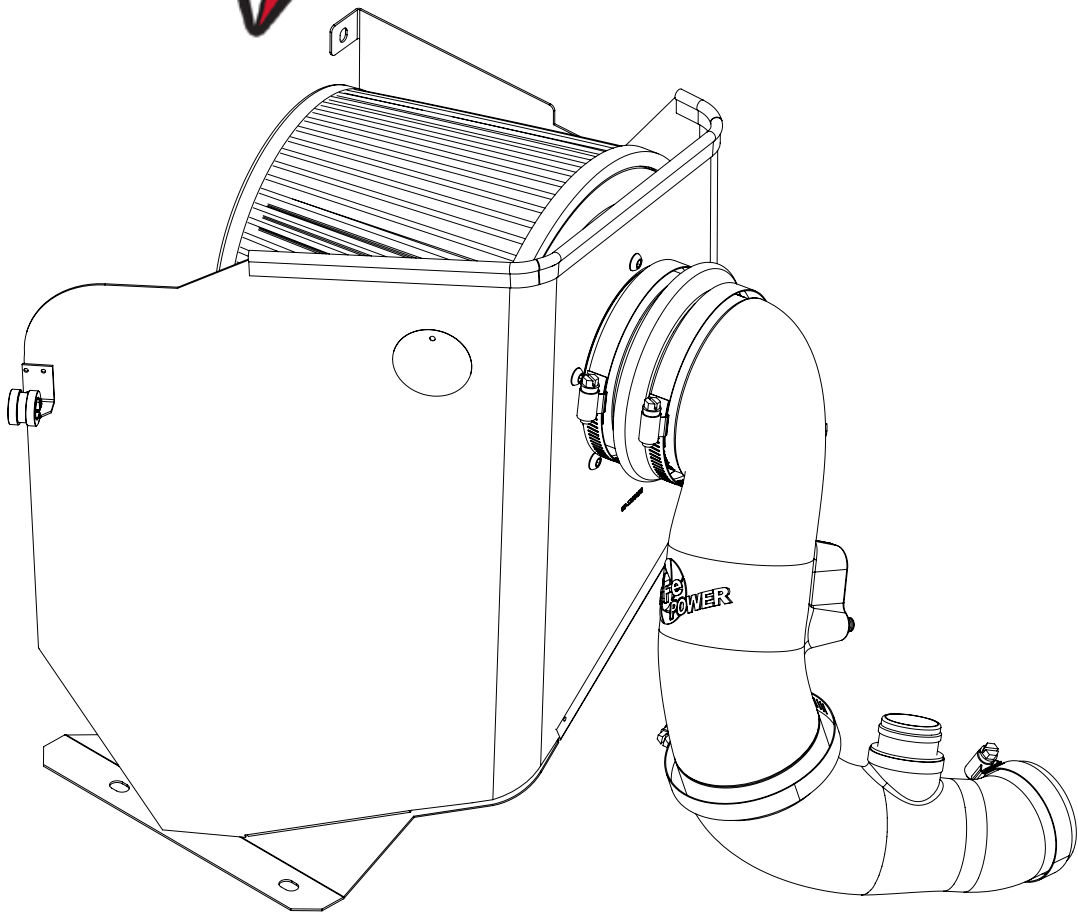

MAGNUM FORCE



advanced FLOW engineering Stage-2 Air Intake

Instruction Manual P/N: 51-12832 / 54-12832 / 75-12832

Make: **Chevrolet**
Make: **GMC**

Model: **Colorado**
Model: **Canyon**

Year: **2016-2020**
Year: **2016-2020**

Engine: **L4-2.8L (td) Duramax (LWN)**
Engine: **L4-2.8L (td) Duramax (LWN)**



- Please read the entire instruction manual before proceeding.
- Ensure all components listed are present.
- If you are missing any of the components, call customer support at 951-493-7100.
- Ensure you have all necessary tools before proceeding.
- Do not attempt to work on your vehicle when the engine is hot.
- Disconnect the negative battery terminal before proceeding.
- Retain factory parts for future use.

Label	Qty.	Description	Part Number
A1	1	Pro DRY S Air Filter	21-91051 (Gray Media)
A2	1	Pro 5R Air Filter	24-91051 (Blue Media)
A3	1	Pro-GUARD 7 Air Filter	72-91051 (Gold Media)
B	1	Housing	05-12832B2
C	1	Tube	05-12832B1
D	5	Screw, Btn Hd Socket:M6x1x10	03-50113
E	2	Screw, Torx: M4x.7x8mm	03-50491
F	1	Screw, Hex Hd: M6x1x12	03-50032
G	1	Nut, Hex Nylon Lock: M6x1.0	03-50185
H	1	Adaptor	05-00611
I	1	Coupling, Silicone Elbow	05-01376
J	1	Coupling, Silicone Hump	05-01399
K	2	Clamp, 064	03-50006
L	1	Clamp, 044	03-50019
M	1	Clamp, 052	05-50008
N	1	Clamp, Fixing: 1/2" ID	03-50377
O	1	Seal, Trim (35" in.)	05-00072
P	1	Seal, Trim (12" in.)	05-00072

Installation will require the following tools:

8mm & 10mm nut driver, flathead screwdriver & #3 Phillips screwdriver, T20 driver, 4mm Allen, 10mm wrench

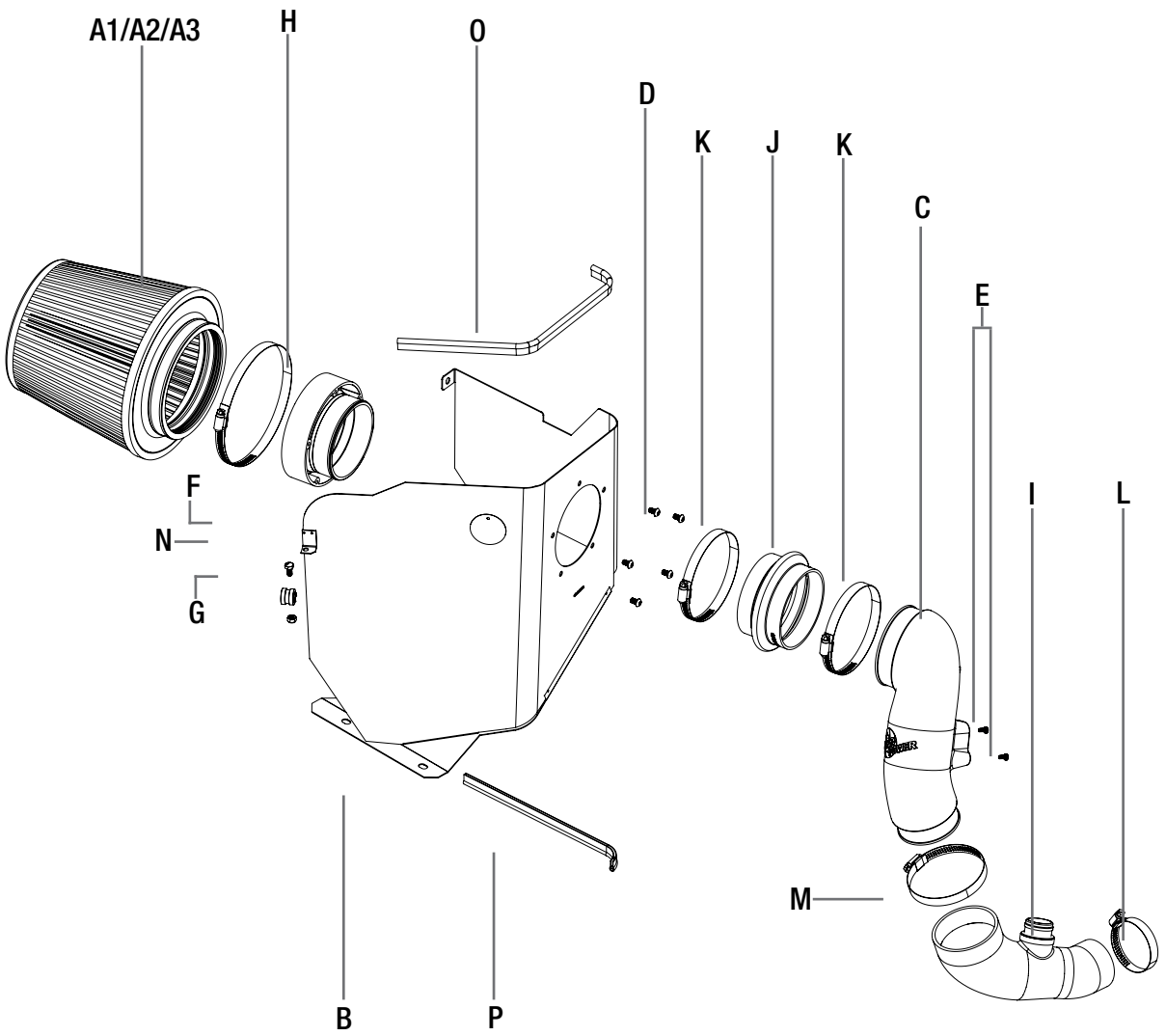

**Figure A****Refer to Figure A for Step 1**

Step 1: Use an 8mm nut driver to loosen the stock clamps (1). Remove the upper intake tube (2).



Figure B

Refer to Figure B for Step 2

Step 2: Disconnect the mass air flow sensor (3). Disengage the wire loom clip (4) from the air box. Remove the upper half of the air box with a #3 Phillips screwdriver and remove the air filter.



Figure C

Refer to Figure C for Step 3

Step 3: Use a 10mm nut driver to remove the two nuts (5) holding the air box and set aside. Remove the air box with the attached air inlet by pulling up to release the air box from its mounting grommet.



Figure D

Refer to Figure D for Step 4

Step 4: Disconnect the breather hose (6) and loosen the clamp (7) at the turbo using an 8mm nut driver. Remove the lower intake tube (8).

Figure E
Refer to Figure E for Step 5

Step 5: Place the supplied #044 clamp (9) on the supplied silicone elbow coupler (10). Install the coupler with clamp on the turbo and tighten the clamp. Connect the breather hose (11).

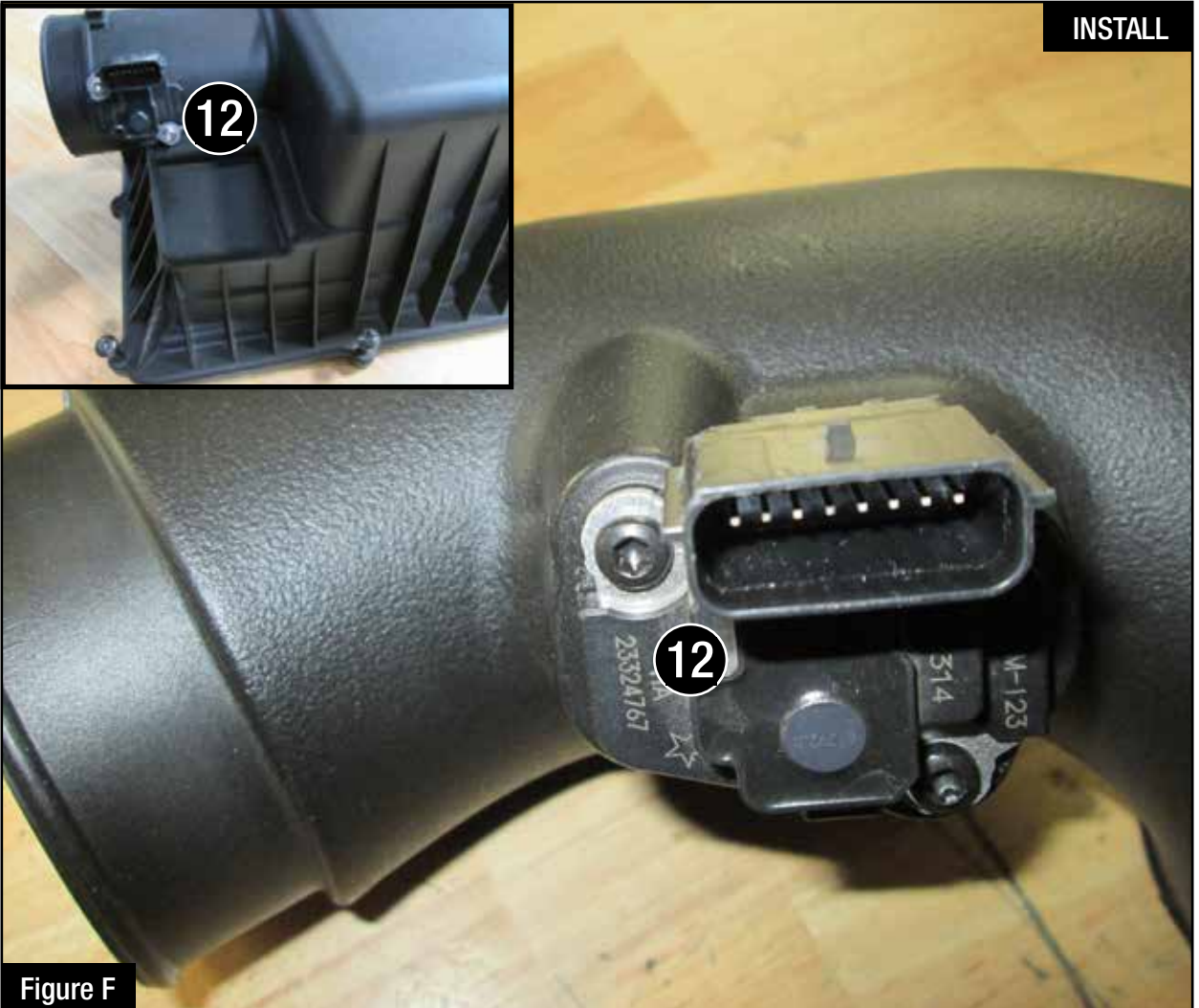

Figure F

Refer to Figure F for Step 6

Step 6: Using a Torx 20 driver, remove the mass air flow sensor (12) from the upper half of the air box and install it on the aFe intake tube with the two supplied screws. Do not overtighten.



Figure G

Refer to Figure G for Step 7

Step 7: Install the filter adaptor (13) on the aFe air filter housing using a 4mm allen wrench and the five supplied button head hex screws.



Figure H

Refer to Figure H for Step 8

Step 8: Install the upper and the lower trim seal (14) onto the aFe air filter housing.

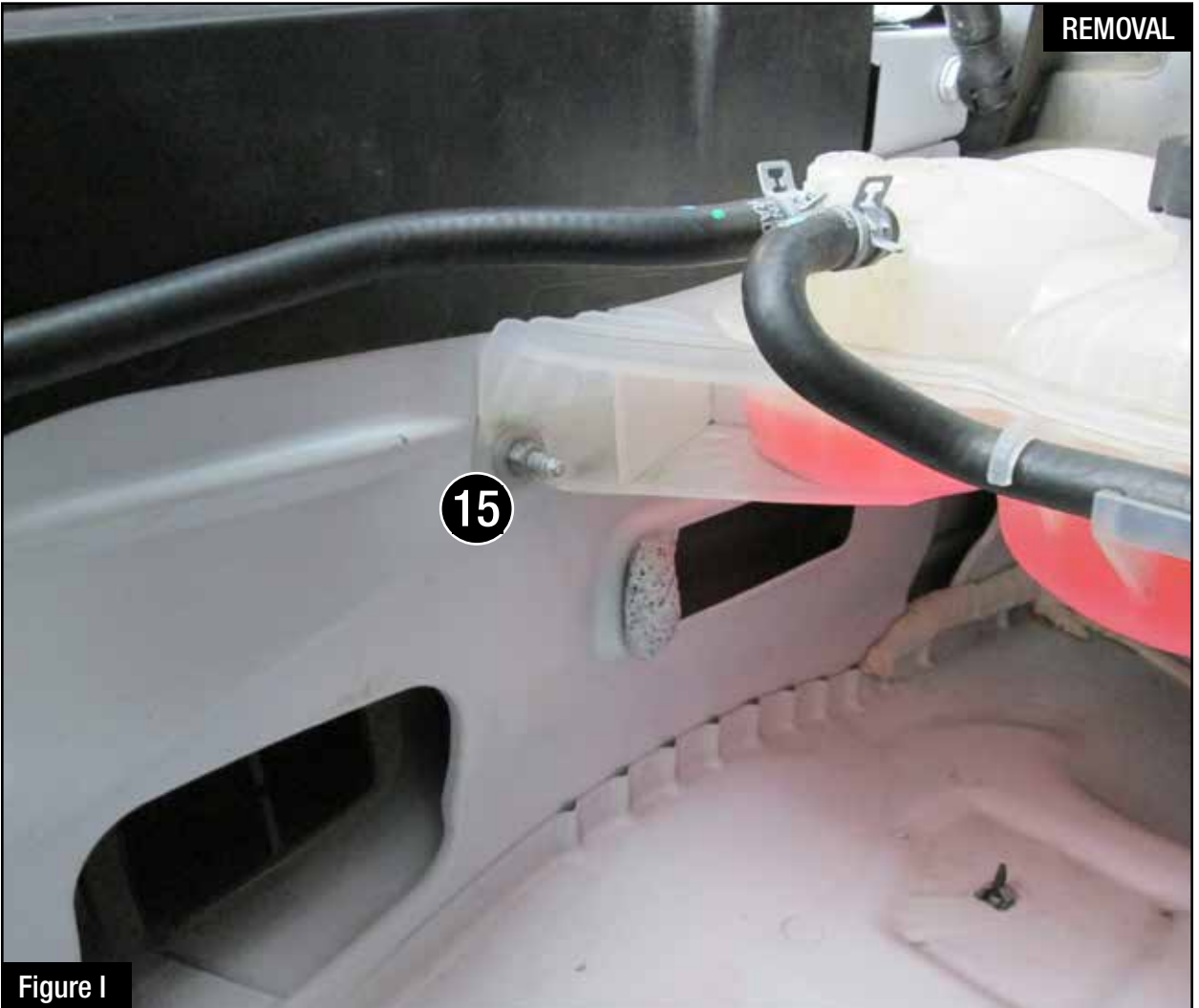
**Figure I****Refer to Figure I for Step 9**

Step 9: Remove the nut (15) from the front of the coolant reservoir using a 10mm nut driver. Save for later use.

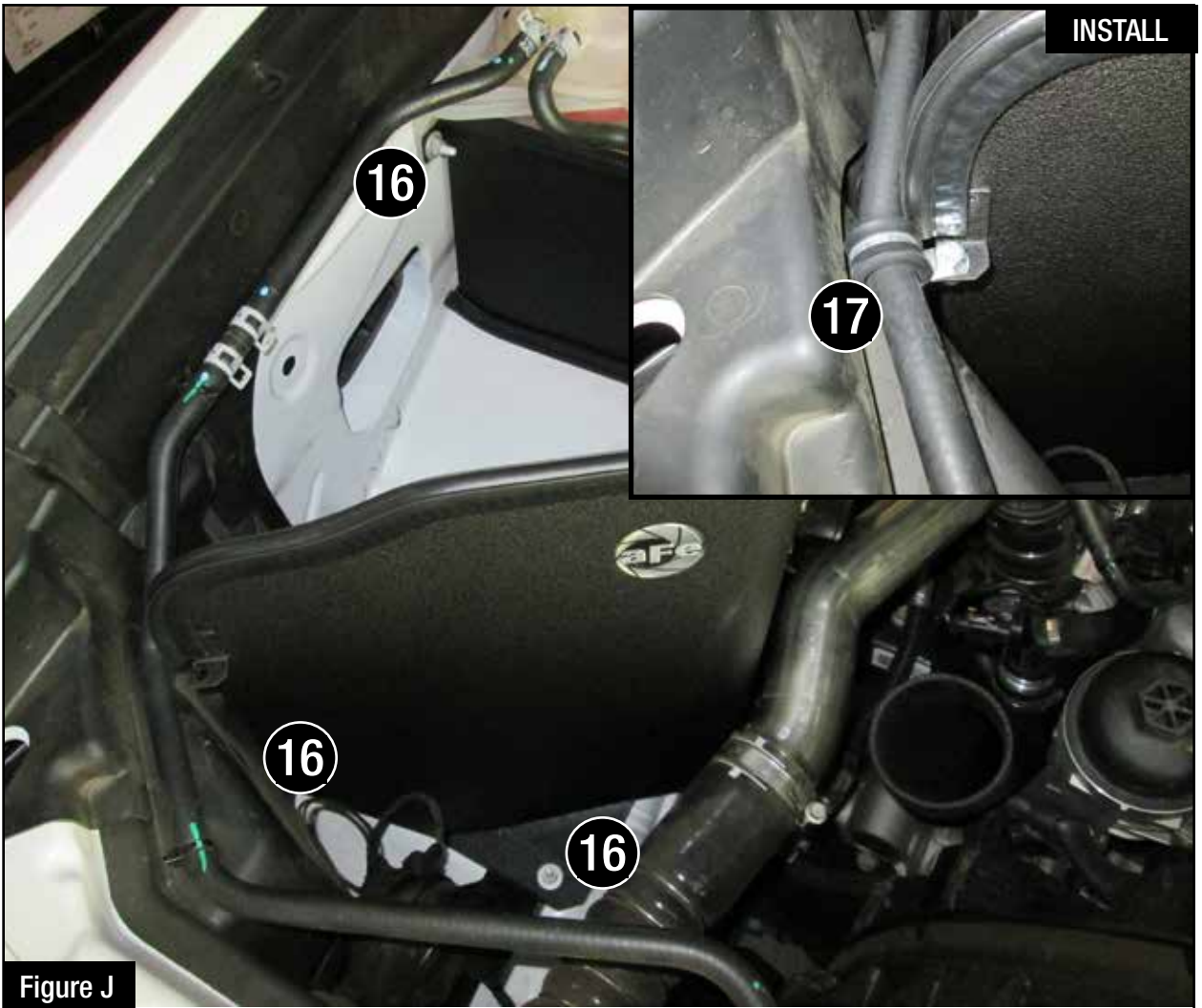

Refer to Figure J for Steps 10-11

Step 10: Install the aFe housing in the vehicle using the three factory nuts (16) and a 10mm nut driver.

Step 11: Install the fixing clamp (17) to the housing and secure the coolant hose with the M6 bolt and nut using a 10mm wrench and a 10mm nut driver.



Figure K

Refer to Figure K for Step 12

Step 12: Install one of the supplied #064 clamps (18) onto the supplied silicone coupler (19). Install the coupler with the clamp onto the air filter adaptor. Place the other #064 clamp on the coupler (18). Do NOT tighten clamps at this time.



Figure L

Refer to Figure L for Step 13

Step 13: Install the supplied #052 clamp (20) on the silicone elbow coupler. Install the aFe intake tube into the vehicle by sliding into the coupler at the air filter first, then slide it into the silicone elbow coupler. Tighten all clamps.



Figure M

Refer to Figure M for Step 14

Step 14: Re-connect the Mass Air Flow Sensor (21).



Figure N

Refer to Figure N for Step 15

Step 15: Install the air filter and tighten the clamp. Your installation is now complete. Thank you for choosing aFe Power!

NOTE: Check all bolts, clamps, and connectors after 200 miles. Place enclosed CARB EO sticker on or near the device on a smooth/clean surface. EO identification label is required to pass the smog test inspection.



Pro DRY S Air Filter



P/N: 21-91051

Pro 5R Air Filter



P/N: 24-91051

Pre-Filter



P/N: 28-10303

Pro DRY S Restore Kit



P/N: 90-59999

Blue Squeeze Restore Kit



P/N: 90-50501

DPF-Back Exhaust System



P/N: 49-44064-B (Blk Tip)
49-44064-P (Pol Tip)

Side-Exit Exhaust System



P/N: 49-44065-B (Blk Tip)
49-44065-P (Pol Tip)

Intercooler Tubes



P/N: 46-20264-B (Blk)
46-20264-R (Red)

SCORCHER HD Module



P/N: 77-44009

Coilovers



P/N: 501-5600-03 (Front)

Shocks



P/N: 502-0052-02 (Rear)

To purchase any of the items above, view airflow charts, dyno graphs, photos, and video; please go to aFepower.com.

Warranty

General Terms:

- aFe warrants their products to be free from manufacturer's defects due to workmanship and material.
- This warranty applies only to the original purchaser of the product and is non-transferrable.
- Proof of purchase of the aFe product is required for all warranty claims.
- Warranty is valid provided aFe instructions for installation and/or cleaning were properly followed.
- Proper maintenance with regular inspections of product is required to insure warranty coverage.
- Damage due to improper installation, abuse, unauthorized repair or alteration is not warranted.
- Incidental or consequential damages or cost, including installation and removal of part, incurred due to failure of aFe product is not covered under this warranty.
- All warranty is limited to the repair and/or replacement of the aFe part. To request Return Goods Authorization ("RGA"), email RGA@afepower.com or call (951)493-7100. Upon receipt of the RGA, you must return the product to the address provided in the RGA, freight prepaid and accompanied with a dated proof of purchase and the RGA. Upon receipt of the defective product and upon verification of proof of purchase, aFe will either repair or replace the defective product within a reasonable time, not to exceed thirty days.

Product Category	P/N Prefix	Warranty duration
Direct OE Replacement Filters	10, 11, 30, 31, 71, 73	Life of the vehicle
Racing Filters	18	1 year
Universal	21, 24, 72	2 years
Air Intake Systems	50, 51, 54, 55, 75	2 years
Exhaust Systems	49	2 years
Intercoolers & Intercooler Tubes	46-2	2 years
Intake Manifolds	46-1	2 years
Differential Cover	46-7	Life of the vehicle
Exhaust Manifolds	46	2 years
Throttle Body Spacers	46-3	2 years
Fluid Filters	44	90 days
Pre-Filters	28	2 years
Heavy Duty OE Replacement	70	2 years
PowerSports OE Replacement	81, 87	2 years
PowerSports Intake Systems	85	2 years

No other warranty expressed or implied applies nor is any person or advanced FLOW engineering authorized to assume any other warranty. Some States do not allow the exclusion or limitation of incidental or consequential damages or do not allow limitations on how long an implied warranty lasts, so the above limitations or exclusions may not apply to you. This warranty gives you specific legal rights, and you may also have other rights which vary from State to State.



advanced FLOW engineering, inc.

252 Granite Street Corona, CA 92879

TEL: 951.493.7155 • TECH: 951.493.7185

E-Mail: Tech@aFepower.com