



advanced FLOW engineering

Instruction Manual

P/N: 77-42012

SCORCHER HD MODULE

Make: Dodge	Model: 1500	Year: 2014-2018
Make: Dodge	Model: 1500 Classic	Year: 2019
Make: Ram	Model: 1500	Year: 2014-2018
Make: Ram	Model: 1500 Classic	Year: 2019

Engine: V6-3.0L (td) EcoDiesel
Engine: V6-3.0L (td) EcoDiesel
Engine: V6-3.0L (td) EcoDiesel
Engine: V6-3.0L (td) EcoDiesel



THIS IS A HIGH-PERFORMANCE PRODUCT: Do not use this product until you have carefully read the following agreement and installation instruction. This sets forth the terms and conditions for the use of this product. The installation of this product indicates that the BUYER has read and understands this agreement and accepts its terms and conditions.

DISCLAIMER OF WARRANTY AND LIMITATION OF LIABILITY: Advanced FLOW Engineering, Inc. (also known as aFe or aFe POWER) and its successors, distributors, jobbers, and dealers (hereafter “SELLER”) shall in no way be responsible for the product’s improper use and service. It is the installer’s responsibility to check for proper installation and if in doubt, contact the manufacturer. The SELLER assumes no liability regarding the improper installation or misapplication of its products. BUYER acknowledges it has had the opportunity to fully inspect the product. Accordingly, BUYER acknowledges that the product is being sold in “AS IS/WHERE IS” condition. SELLER shall not be held liable for special, indirect, incidental or consequential damages of any nature with respect to the products (including, without limitation, lost profits, lost sales, loss of production, property damage, personal injury or loss or damage resulting from interruption or failure in operation of the products) and BUYER hereby expressly waives and disclaims all such liability claims. The BUYER acknowledges and agrees that the disclaimer of liability contained herein is a material term of the sale of the product and, to the fullest extent permitted by law, BUYER shall defend, indemnify and hold SELLER harmless from any and all claims, demands, causes of action, controversies, liabilities, fines, losses, costs and expenses (including, but not limited to attorneys’ fees, expert witness expenses and litigation expenses) arising from or related to SELLER’s products.

Before proceeding with the installation:

- Please read the entire instruction manual before proceeding.
- Ensure all components listed are present.
- If you are missing any of the components, call customer support at 951-493-7185.
- Ensure you have all necessary tools before proceeding. Do not attempt to work on your vehicle when the engine is hot.

Emission Disclaimer: This product is not currently CARB exempt and is not available for purchase in California or for use on any vehicle registered with the California Department of Motor Vehicles.



Label	Qty.	Description	Part Number
A	1	Module	R77-42012
B	1	LED Switch	05-70029
C	2	Velcro (2" Inches)	05-01244
D	4	Cable Ties	05-60167





SLEEP MODE

Figure A

Refer to Figure A for Step 1

Step 1: Before installing your aFe POWER module, you will have to place your vehicle's ECU in sleep mode. In order to do this, you will need to do the following:

- If the engine is cold: open the hood, close the doors, lock the car and wait 30 seconds.
- If the engine is warm: open the hood, close the doors, lock the car and wait 20 minutes.
- If the engine is warm and you can't wait 20 minutes: disconnect the battery.

 **Note: Do NOT open doors or start vehicle while one of the sensors is disconnected. This could create a check engine light**

**Figure B****Refer to Figure B for Step 2**

Step 2: Remove your engine cover and the foam insulation on the passenger side to gain access to the MAP and Fuel Pressure Sensors

 **Note: Removal of the intake tube is not necessary, but can give you more clearance while working with the connectors if needed.**

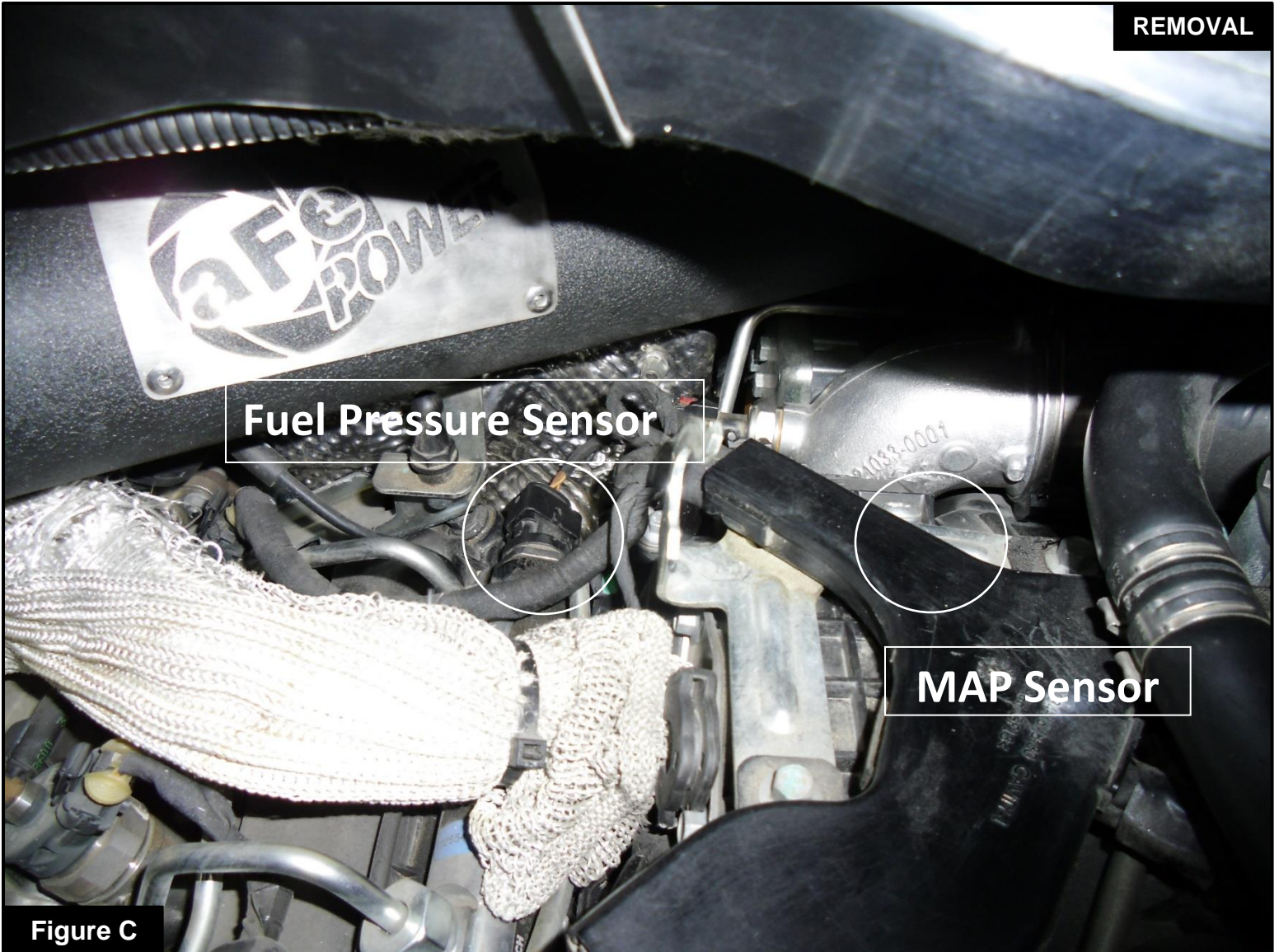
**Figure C****Refer to Figure C for Step 3**

Step 3: Locate the MAP and Fuel Pressure sensors. The MAP sensor is located on the back of the intake manifold, just in front of the turbo. The fuel pressure sensor is located at the end of the fuel rail, near the firewall, and just to the left of the MAP sensor.

**Figure D****Refer to Figure D for Steps 4-5**

Step 4: Locate, and then disconnect the MAP sensor connector, by pressing down on the locking tab of the connector and sliding it out of the sensor.

Step 5: Locate the MAP sensor jumper harness on the aFe POWER harness. This is the shorter jumper harness with the larger connectors. It will be labeled MAP. Plug the female connector of the aFe POWER harness into the MAP sensor, then take the male connector of the aFe POWER harness and connect to the female connector of the engine harness.



Refer to Figure E for Step 6

Step 6: Check with the pictures to make sure the connectors are fully seated in the right orientation.

 **Make sure that the connections are fully engaged. Usually, connectors make a snapping sound when fully engaged**

**Figure F****Refer to Figure F for Steps 7-8**

Step 7: Disconnect the Fuel Pressure Sensor connector by pressing down on the locking tab of the connector and sliding it out of the sensor.

Step 8: Locate the Fuel Pressure sensor jumper harness on the aFe POWER harness. This is the longer harness with the smaller connectors. It is labeled FUEL. Plug the female connector of the aFe POWER harness into the fuel pressure sensor, then the male connector of the aFe POWER harness to the female connector of the engine harness.



Note: The locking tab of this connector may not be visible. It is connected the same way as the MAP sensor.

**Figure G****Refer to Figure G for Step 9**

Step 9: Check with the pictures to make sure the connectors are fully seated in the right orientation.



Make sure that the connections are fully engaged. Usually, connectors make a snapping sound when fully engaged.



Figure H

Refer to Figure H for Steps 10-11

Step 10: Select the desired location for the LED switch. Route the cable on the back of the switch to exit towards the top or the bottom.

Step 11: Use the provided double sided tape to secure the LED switch in the desired location.

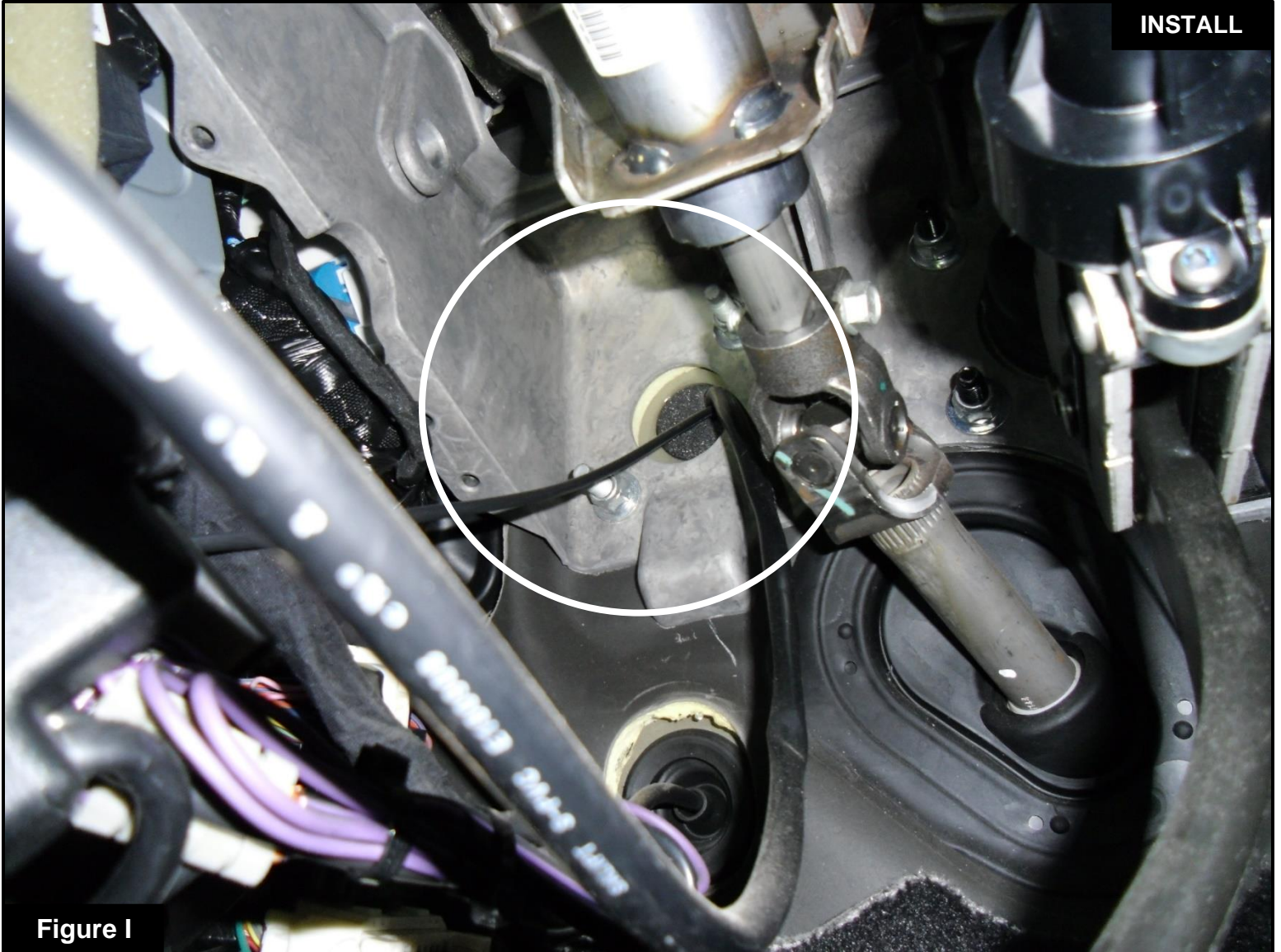

Figure I

Refer to Figure I for Steps 12-14

Step 12: Carefully route the switch cable behind steering wheel cover or cabin trim cover

Step 13: Route the switch cable through the firewall and into the engine bay. Follow the main harness through the grommet into the firewall. Alternatively, there is an opening above the harness that can be poked through by using a screwdriver.

Step 14: Plug the end of the switch cable to the harness inside the engine compartment.

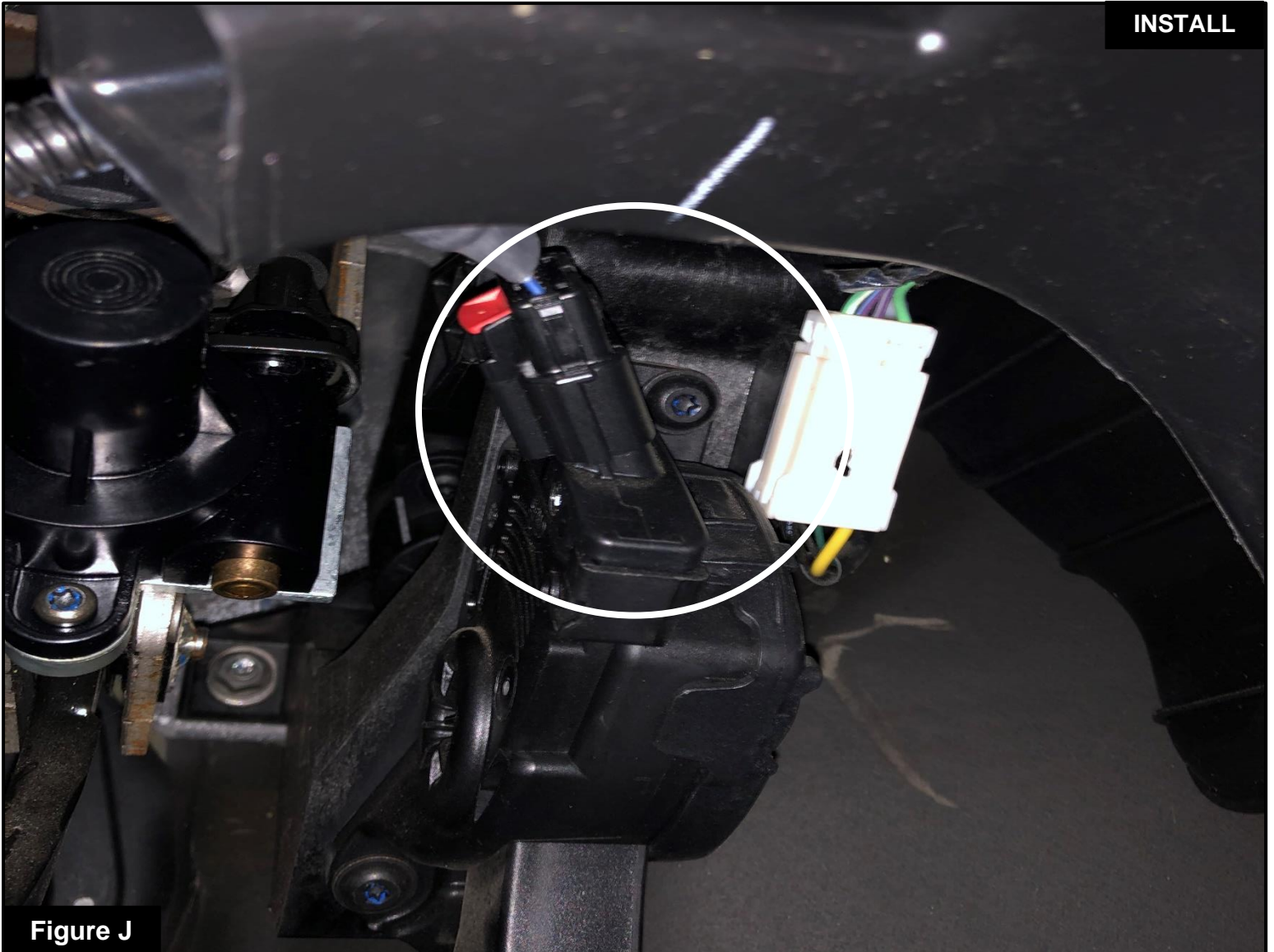
**Figure J****Refer to Figure J for Steps 15-16**

Step 15: Locate the connector for the gas pedal. It is located towards the top of the gas pedal assembly.

Step 16: Disconnect the gas pedal harness by pressing in on the locking tab and sliding the connector out of the gas pedal assembly.

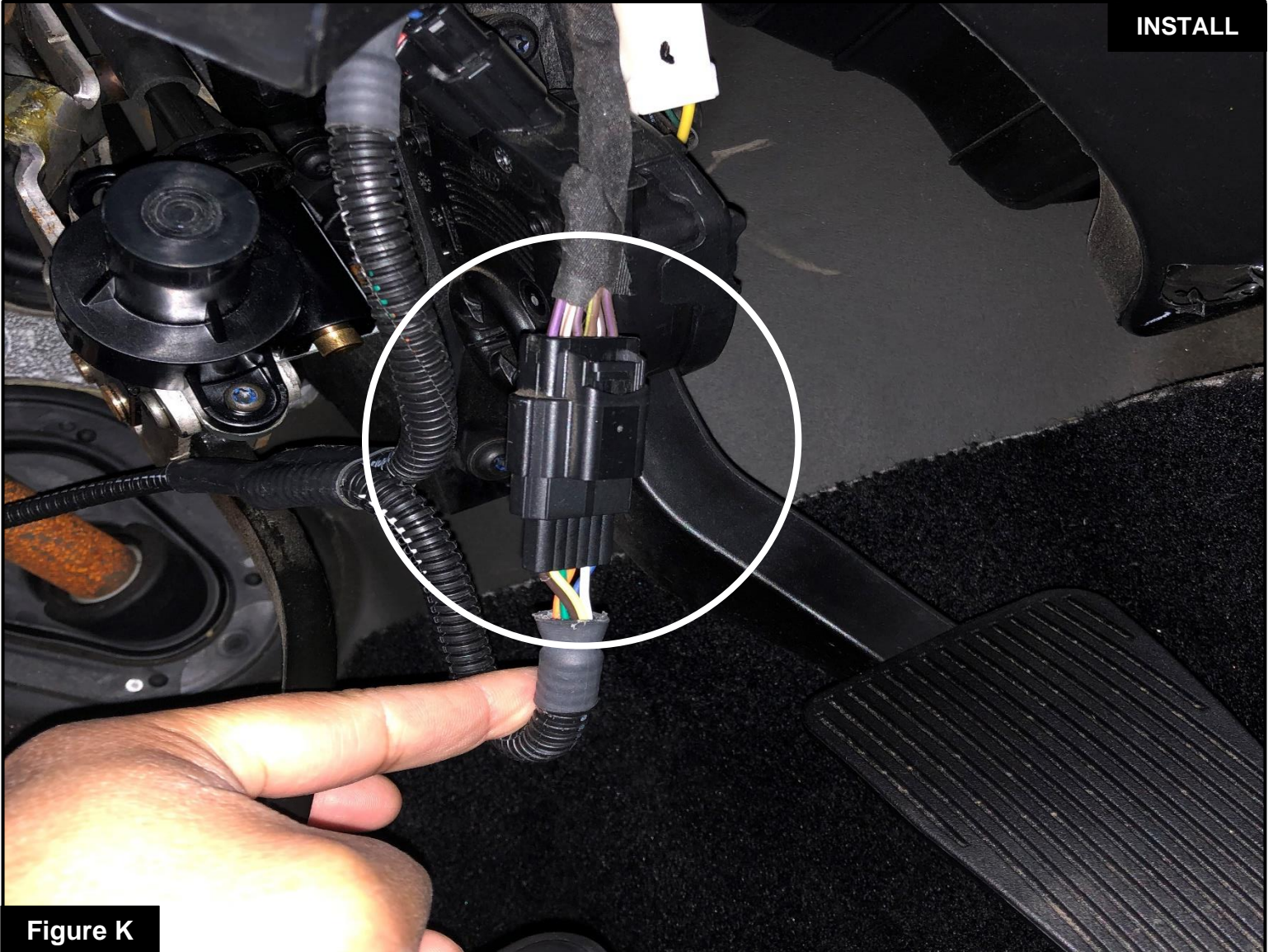
**Figure K****Refer to Figure K for Steps 17-18**

Step 17: Locate the gas pedal harness. It is labeled pedal. Plug the female connector of the aFe POWER harness into the male connector of the gas pedal assembly. Then plug the male connector of the aFe POWER harness into the female connector of the gas pedal harness.

Step 18: Utilizing either the opening for the engine harness or the opening above it, run the wires for the gas pedal harness back into the engine bay and plug it into the harness on the aFe POWER module. Use the provided cable ties to secure the harness under the steering wheel to make sure it does not interfere with your foot or the accelerator pedal.

 **Make sure that the connections are fully engaged. Usually, connectors make a snapping sound when fully engaged.**



Figure L

Refer to Figure L for Steps 19-21

Step 19: Secure the Scorch HD module to the fuse box cover on the driver side or any other desired location using the Velcro provided.

Step 20: Secure the wires away from any extreme heat and moving parts with the provided zip ties.

Step 21: Reinstall the insulation foam and engine cover.



Figure M

Refer to Figure M (LED Switch)

When turning on the vehicle, each LED will flash, and it will stop at its last setting. The LED on the switch represents the different level of power.

- Green LED: Stock
- Yellow LED: Sport
- Orange LED: Sport+
- Red LED: Race

Use the grey button to select the desired setting. Power adjustments can be done at any time while the unit is on. Thank you for choosing aFe POWER.



Page left blank intentionally.

Intercooler w/ Tubes



P/N: 46-20172

Rear Differential Cover



P/N: 46-70272-WL (w/ Oil)
46-70272 (Blk)
46-70272 (RAW)

Engine Oil Pan



P/N: 46-70282 (Blk)
46-70280 (RAW)

Momentum HD Intake



P/N: 54-72006 (P5R)
51-72006 (PDS)

Momentum HD Intake Scoop



P/N: 54-72006-S

DPF-Back Exhaust System

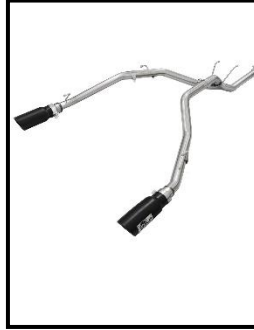

P/N: 49-42041-B (Blk Tips)
49-42041-P (Pol Tips)

Intercooler Tubes



P/N: 46-20174-B (Black)
46-20174-R (Red)

OE Replacement Air Filter



P/N: 30-10071 (P5R)
31-10071 (PDS)

To purchase any of the items above, view airflow charts, dyno graphs, photos, and video; please go to aFepower.com.



Warranty

General Terms:

- aFe warrants their products to be free from manufacturer's defects due to workmanship and material.
- This warranty applies only to the original purchaser of the product and is non-transferrable.
- Proof of purchase of the aFe product is required for all warranty claims.
- Warranty is valid provided aFe instructions for installation and/or cleaning were properly followed.
- Proper maintenance with regular inspections of product is required to insure warranty coverage.
- Damage due to improper installation, abuse, unauthorized repair or alteration is not warranted.
- Incidental or consequential damages or cost, including installation and removal of part, incurred due to failure of aFe product is not covered under this warranty.
- All warranty is limited to the repair and/or replacement of the aFe part. To request Return Goods Authorization ("RGA"), email RGA@afepower.com or call (951)493-7100. Upon receipt of the RGA, you must return the product to the address provided in the RGA, freight prepaid and accompanied with a dated proof of purchase and the RGA. Upon receipt of the defective product and upon verification of proof of purchase, aFe will either repair or replace the defective product within a reasonable time, not to exceed thirty days.

Product Category	P/N Prefix	Warranty duration
Direct OE Replacement Filters	10, 11, 30, 31, 71, 73	Life of the vehicle
Racing Filters	18	1 year
Universal	20, 21, 23, 24, 72, TF	2 years
Air Intake Systems	50, 51, 53, 54, 55, 56, 57, 58, 75, TR, TA, TL, TM	2 years
Exhaust Systems	49	2 years
Intercoolers & Intercooler Tubes	46-2	2 years
Intake Manifolds	46-1	2 years
Differential Cover	46-7	Life of the vehicle
Exhaust Manifolds	46	2 years
Throttle Body Spacers	46-3	2 years
Turbochargers	46-6	2 years*
Fluid Filters	44	90 days
Pre-Filters	28	2 years
Heavy Duty OE Replacement	70	2 years
PowerSports OE Replacement	81, 87	2 years
Tuners	77	1 year

No other warranty expressed or implied applies nor is any person or advanced FLOW engineering authorized to assume any other warranty. Some States do not allow the exclusion or limitation of incidental or consequential damages or do not allow limitations on how long an implied warranty lasts, so the above limitations or exclusions may not apply to you. This warranty gives you specific legal rights, and you may also have other rights which vary from State to State.

*See turbocharger warranty for more info



advanced FLOW engineering, inc.

252 Granite Street Corona, CA 92879
TEL: 951.493.7100 • TECH: 951.493.7185
E-Mail: Tech@aFepower.com

P/N: 06-81348

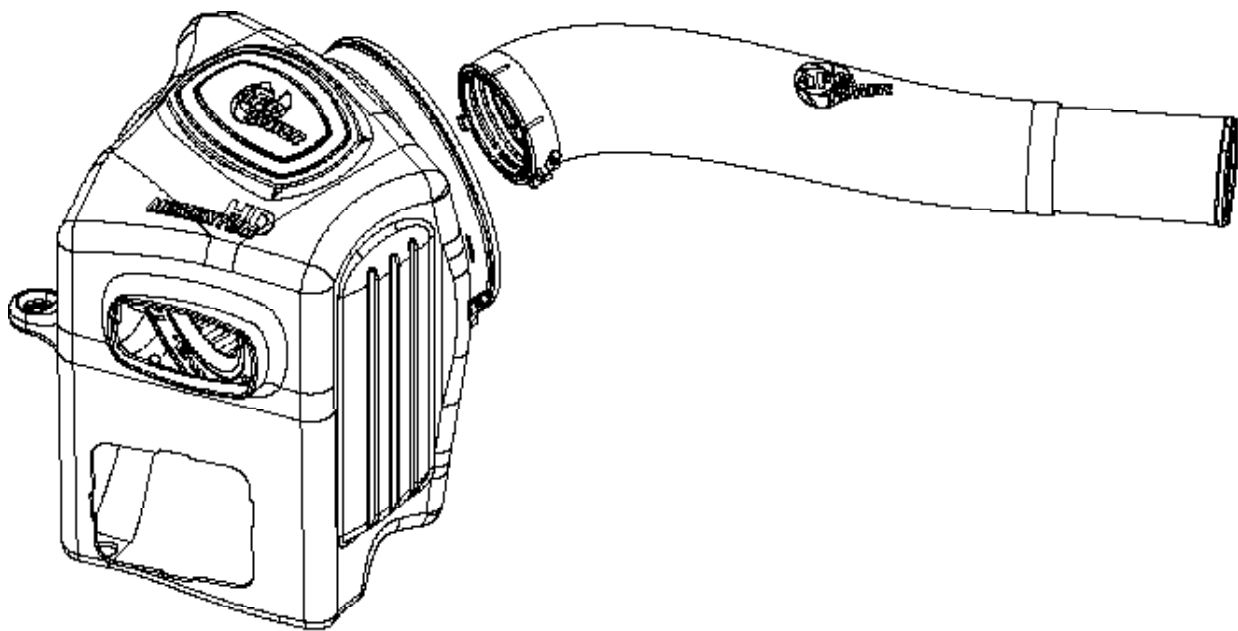

advanced FLOW engineering

Instruction Manual P/N: 51-72006 / 54-72006

Make: **RAM** Model: **1500/1500 Classic EcoDiesel** Year: **2014-2019** Engine: **V6-3.0L (td)**



- Please read the entire instruction manual before proceeding.
- Ensure all components listed are present.
- If you are missing any of the components, call customer support at 951-493-7100.
- Ensure you have all necessary tools before proceeding.
- Do not attempt to work on your vehicle when the engine is hot.
- Disconnect the negative battery terminal before proceeding.
- Retain factory parts for future use.

Label	Qty.	Description	Part Number
A1	1	Air Filter (Pro DRY S)	21-91100
A2	1	Air Filter (Pro 5R)	24-91100
B	1	Tube	05-72006B1
C	1	Housing	05-72006B2
D	1	Clamp, T-Bolt (8-5/16" - 8-5/8")	03-50267
E	1	Coupling, Adaptor	05-01345
F	1	Clamp, T-Bolt (3-3/4"-4-1/16") SS	03-50265
G	1	Plug, Urethane	05-01202

Tools needed: Torx T20 driver, 1/4" Drive Socket Wrench, 8mm Shallow Socket, 10mm Deep Socket, 11mm Deep Socket

Recommended: Acetone, WD-40, Hairspray (Aqua Net)

NOTE: OE air scoop and MAF cartridge are not included with this kit.

Note: Legal in California for use on race vehicles only. The use of this device on vehicles used on public streets or highways is strictly prohibited in California and others states that have adopted California emission regulations.

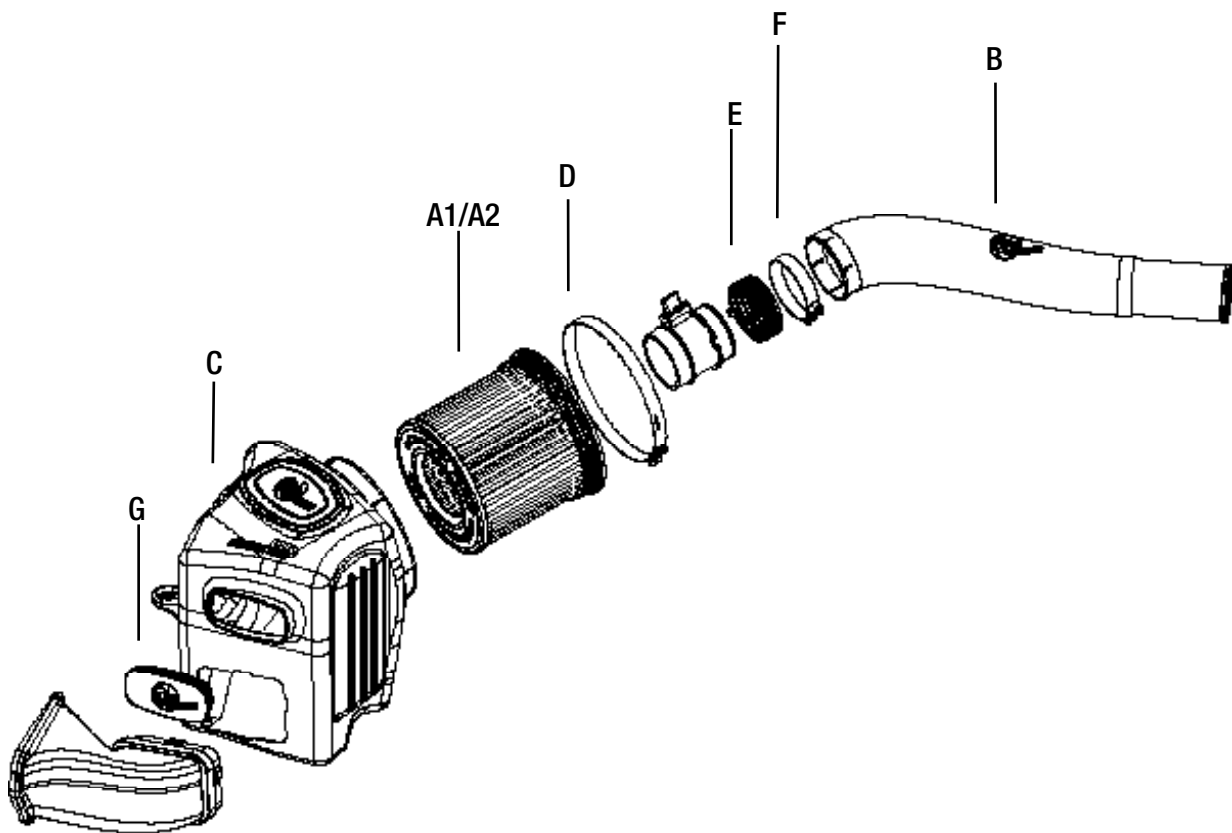

**Figure A****Refer to Figure A for Steps 1-2**

- Step 1: Remove the engine cover by first lifting upward then pulling the cover towards you.
- Step 2: Disconnect the MAF (mass air flow) sensor wiring harness (1) by first pulling on the red clip, then squeeze the sensor and pull.

**Figure B****Refer to Figure B for Step 3**

Step 3: Loosen the clamp at the MAF cartridge ② and compress back.



Figure C

Refer to Figure C for Step 4

Step 4: Remove the entire OE intake assembly by firmly lifting up to clear the plastic mounting pegs and then twisting the assembly towards you.



Figure D

Refer to Figure D for Steps 5-6

Step 5: Using your 8mm shallow socket, loosen the clamp ③ at the turbo adaptor boot.

Step 6: Remove the stock intake tube by pulling up and out towards you, off its mounting peg.

**Figure E****Refer to Figure E for Steps 7-8**

Step 7: Apply a small amount of lubricant (WD-40 recommended) to the AL end of the aFe tube and insert (4) into the OE turbo adaptor boot. Do not tighten the clamp yet.

Step 8: Slip one of the smaller t-bolt clamps (5) over the tube as shown. Do not tighten at this time.

**Figure F****Refer to Figure F for Steps 9-10**

Step 9: Using a T20 Torx driver, remove both screws ⑥ securing the MAF cartridge to the OE intake housing.

Step 10: Remove the O-ring on the MAF cartridge.

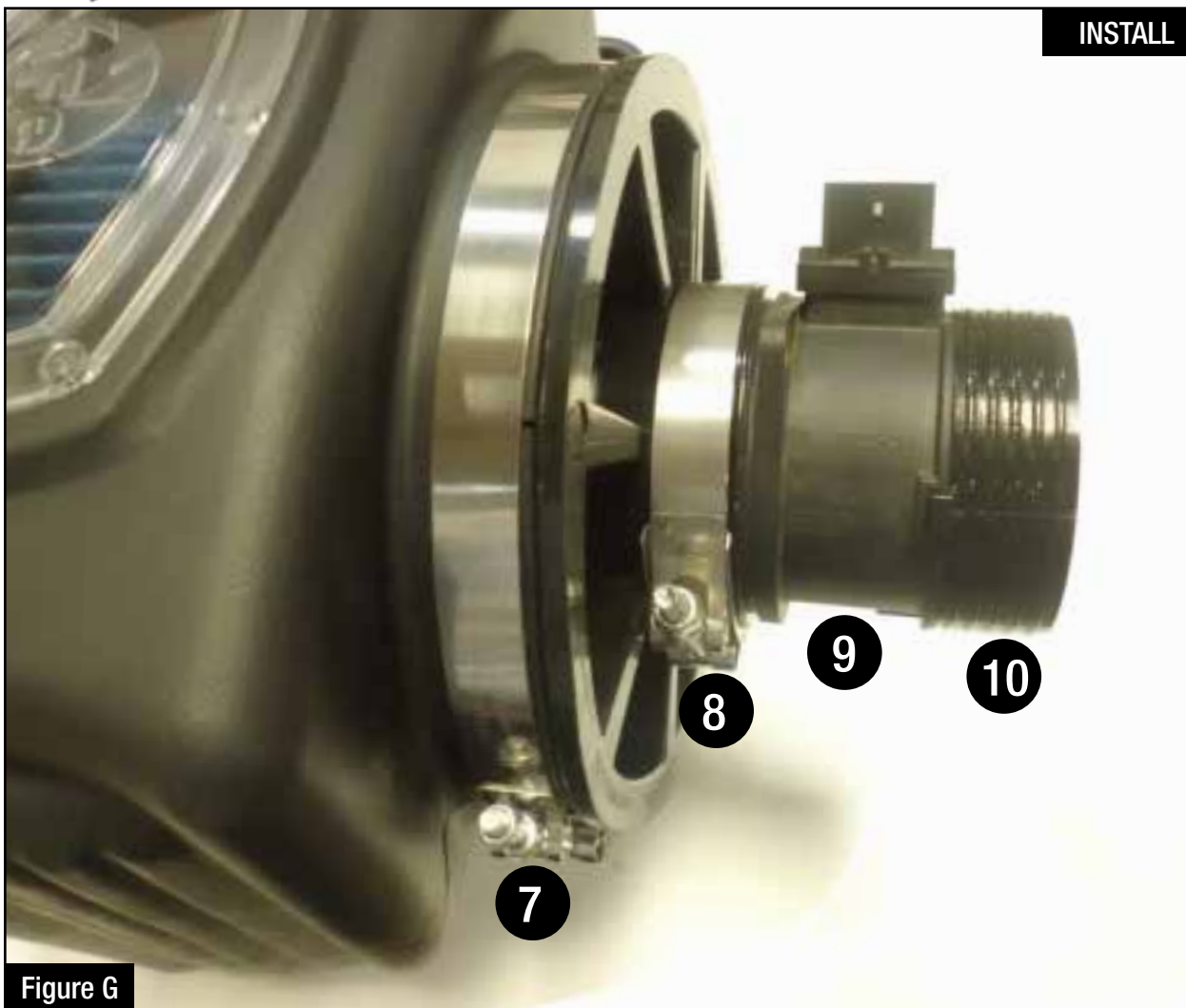
Figure G

Refer to Figure G for Steps 11-16

Step 11: Slip the large t-bolt clamp (7) over the aFe housing as shown.

Step 12: Clean the inside of the rotomold housing flange and both mating surfaces of the filter flange (acetone recommended).

Step 13: Insert filter & t-bolt clamp (8) into the housing as shown. Tighten large t-bolt clamp at this time.

Step 14: Insert the MAF cartridge into the filter flange (9) as shown. Tighten the small t-bolt clamp at this time.

*NOTE: Be careful not to overtighten the t-bolt clamp on the MAF cartridge.

Step 15: Slide the provided polyurethane adaptor coupling (10) over the MAF cartridge, lining up the locator tabs.

Step 16: Clean the mating surface of the polyurethane adaptor coupling using acetone.

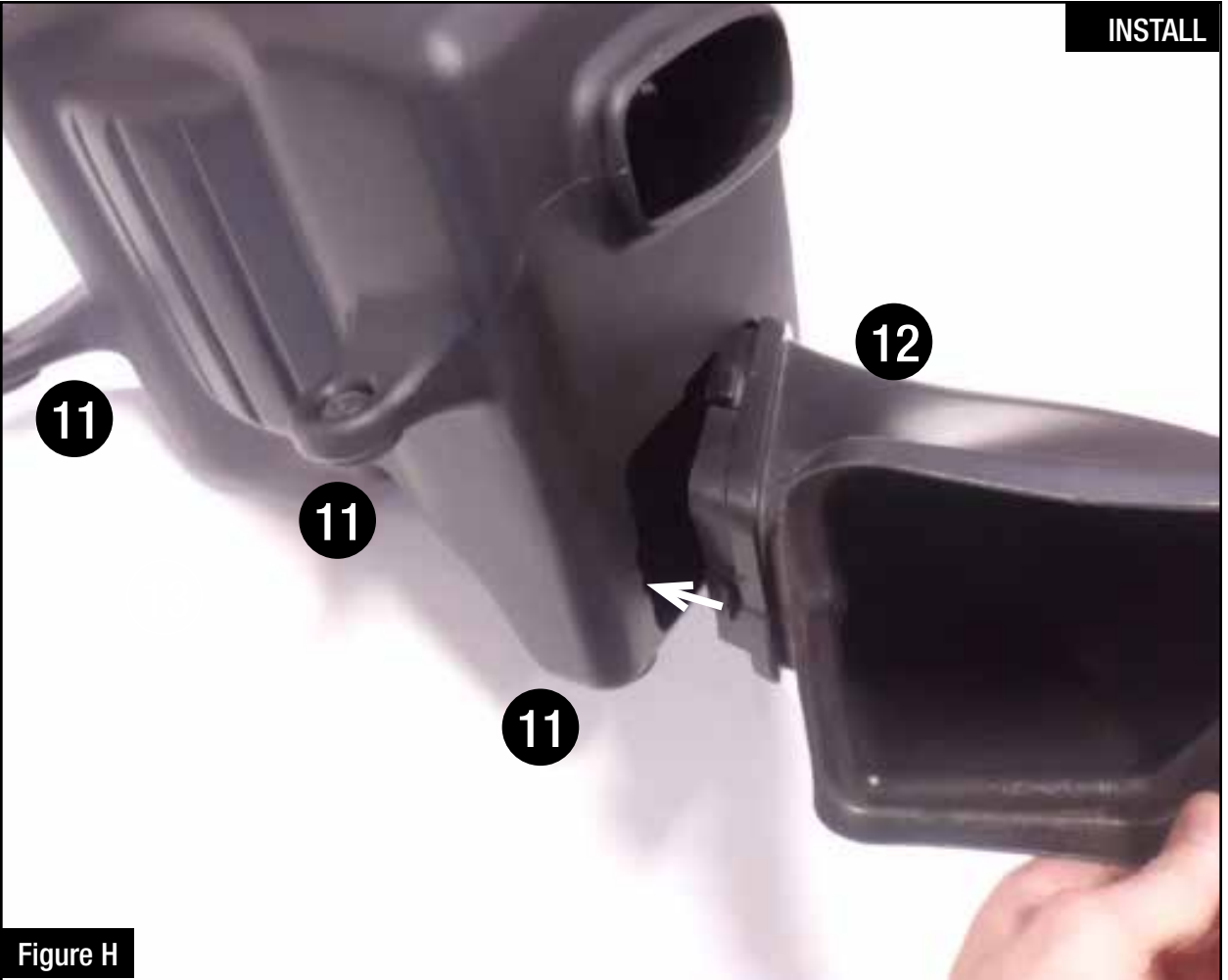
**Figure H****Refer to Figure H for Steps 17-18**

Step 17: Transfer 3 rubber grommets (11) from the OE air box to the aFe housing in the locations shown.

Step 18: Transfer the OE air scoop to the aFe housing (12), starting with one end in first then rotate the other end in until you feel it “lock” into place.

Figure I

Refer to Figure I for Steps 19-22

- Step 19: Spray a little hair spray onto the mating surface of the urethane adaptor coupling.
- Step 20: Apply some WD-40 to the inside of the rubber grommets; this helps them slide over the plastic mounting locations easier.
- Step 21: Lower the intake assembly into the engine bay as shown; roughly lining up the three mounting locations.
- Step 22: Be certain the lower grommet is properly aligned with its plastic mounting peg first. Once all 3 grommets are aligned with the mounting pegs, firmly press down on the housing.



Figure H

Refer to Figure H for Steps 23-27

Step 23: Align the tube with the MAF cartridge and then slip the tube over the polyurethane adaptor up to the 2 locator tabs.

Step 24: Tighten the t-bolt clamp (13) over the MAF cartridge.

*NOTE: Be careful not to overtighten the t-bolt clamp on the MAF cartridge.

*NOTE: Give the hair spray enough time to dry properly before driving vehicle.

Step 25: Reconnect the MAF sensor (14) to the MAF cartridge as shown and push the red clip to secure.

Step 26: Tighten the clamp (15) at the turbo adaptor boot.

Step 26: Make sure all clamps and connections are secure at this time.

Step 27: Reinstall the engine cover (16) at this time.

Your installation is now complete!

*Verify all connections are secure 100-200 miles after installation.



PRO DRY S Air Filter



P/N: 21-91100

PRO 5R Air Filter



P/N: 24-91100

PRO GUARD 7 Air Filter



P/N: 72-91100

Blue Aerosol Restore Kit



P/N: 90-50001

Blue Squeeze Restore Kit



P/N: 90-50501

DPF Back Exhaust



P/N: 49-42044-B

Differential Cover



P/N: 46-70272

Intercooler Tubes



P/N: 46-20174-B

Air Intake



P/N: 54-32572

DPF Back Exhaust



P/N: 49-42041-P

Intercooler Couplings



P/N: 46-20170A

Intercooler Tube



P/N: 46-20179-B

To purchase any of the items above, view airflow charts, dyno graphs, photos, and video; please go to aFepower.com.

Warranty

General Terms:

- aFe warrants their products to be free from manufacturer's defects due to workmanship and material.
- This warranty applies only to the original purchaser of the product and is nontransferable.
- Proof of purchase of the aFe product is required for all warranty claims.
- Warranty is valid provided aFe instructions for installation and/or cleaning were properly followed.
- Proper maintenance with regular inspections of product is required to insure warranty coverage.
- Damage due to improper installation, abuse, unauthorized repair or alteration is not warranted.
- Incidental or consequential damages or cost, including installation and removal of part, incurred due to failure of aFe product is not covered under this warranty.
- All warranty is limited to the repair and/or replacement of the aFe part. To request Return Goods Authorization ("RGA"), email RGA@afepower.com or call (951)493-7100. Upon receipt of the RGA, you must return the product to the address provided in the RGA, freight prepaid and accompanied with a dated proof of purchase and the RGA. Upon receipt of the defective product and upon verification of proof of purchase, aFe will either repair or replace the defective product within a reasonable time, not to exceed thirty days.

Product Category	P/N Prefix	Warranty duration
Direct OE Replacement Filters	10, 11, 30, 31, 71, 73	Life of the vehicle
Racing Filters	18	1 year
Universal	21, 24, 72	2 years
Air Intake Systems	50, 51, 54, 55, 75	2 years
Exhaust Systems	49	2 years
Intercoolers & Intercooler Tubes	46-2	2 years
Intake Manifolds	46-1	2 years
Differential Cover	46-7	Life of the vehicle
Exhaust Manifolds	46	2 years
Throttle Body Spacers	46-3	2 years
Fluid Filters	44	90 days
Pre-Filters	28	2 years
Heavy Duty OE Replacement	70	2 years
PowerSports OE Replacement	81, 87	2 years
PowerSports Intake Systems	85	2 years

No other warranty expressed or implied applies nor is any person or advanced FLOW engineering authorized to assume any other warranty. Some States do not allow the exclusion or limitation of incidental or consequential damages or do not allow limitations on how long an implied warranty lasts, so the above limitations or exclusions may not apply to you. This warranty gives you specific legal rights, and you may also have other rights which vary from State to State.



advanced FLOW engineering, inc.
252 Granite Street Corona, CA 92879
TEL: 951.493.7155 • TECH: 951.493.7185
E-Mail: Tech@aFepower.com

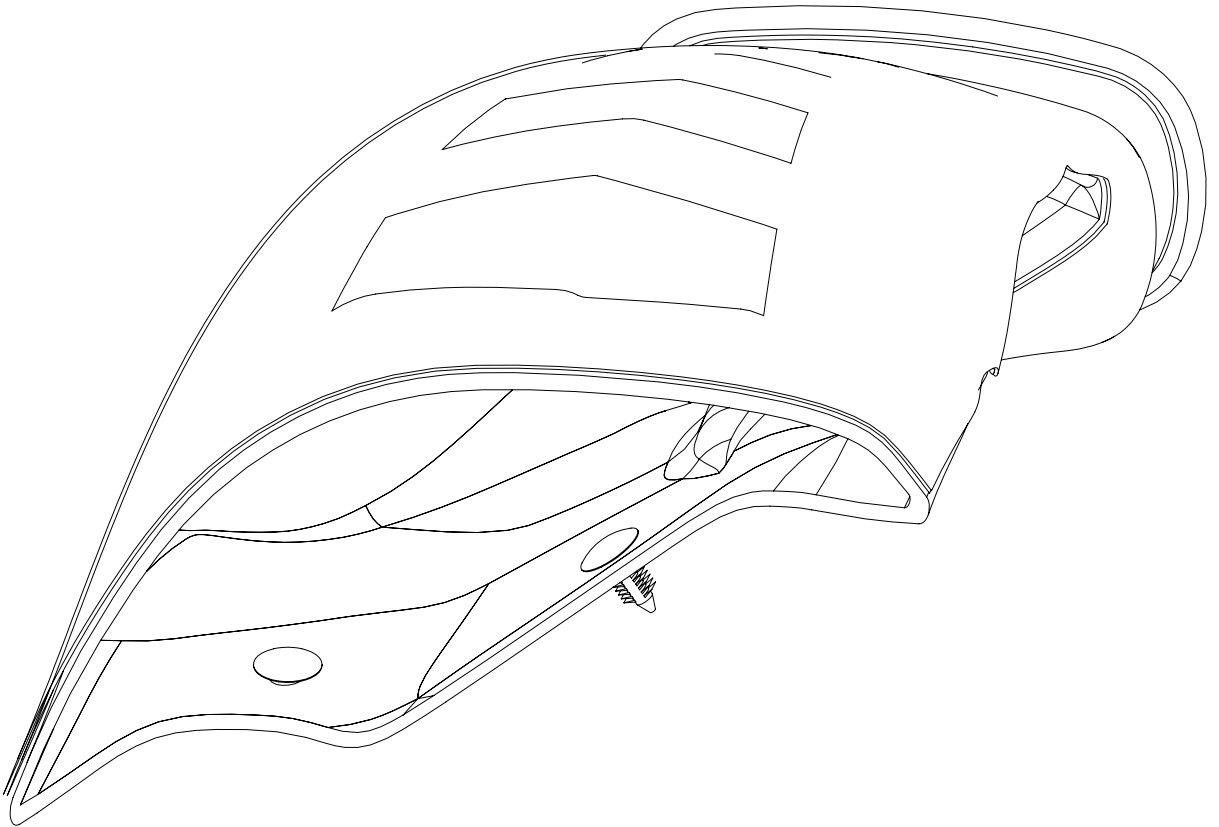

advanced FLOW engineering

Instruction Manual P/N: 54-72006-S

Make: **RAM** Model: **1500 EcoDiesel** Year: **2014-2018** Engine: **V6-3.0L (td)**



- Please read the entire instruction manual before proceeding.
- Ensure all components listed are present.
- If you are missing any of the components, call customer support at 951-493-7100.
- Ensure you have all necessary tools before proceeding.
- Do not attempt to work on your vehicle when the engine is hot.

Retain factory parts for future use.

Label	Qty.	Description	Part Number
A	1	Scoop, Rotomold	05-72006B3
B	2	Retainer Clip, 1/4"	05-01350

Installation will require the following tools:

Drill, 1/4" drill bit, marker, or punch to mark hole location, pliers.

Note: Legal in California for use on race vehicles only. The use of this device on vehicles used on public streets or highways is strictly prohibited in California and others states that have adopted California emission regulations.

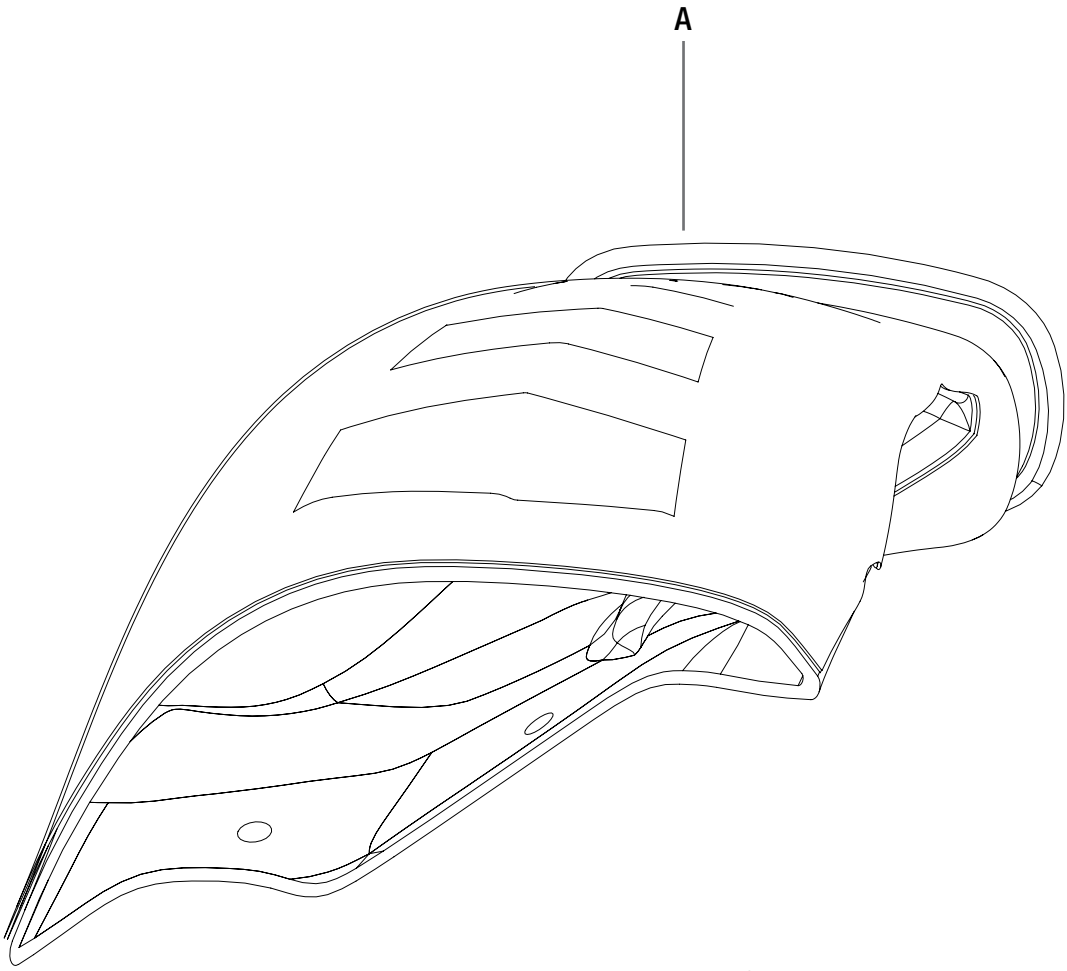

B



Figure A

Refer to Figure A for Step 1

Step 1: Place the scoop into the truck as shown.



Figure B

Refer to Figure B for Step 2

Step 2: While holding the scoop snug against the aFe housing, align the bottom of the scoop flush with the factory plastic trim piece and mark the center of each hole ①.



Figure C

Refer to Figure C for Step 3

Step 3: Drill a 1/4" hole at each point you just marked ②.



Figure D

Refer to Figure D for Step 4

Step 4: Support the bottom of the factory plastic trim and firmly press a retainer clip into each hole.

Your installation is now complete. Thank you for choosing aFe Power!



Page left blank intentionally

Page left blank intentionally



Air Intake System



P/N: 54-72006 (P5R)
51-72006 (PDS)

Rear Differential Cover



P/N: 46-70272-WL (w/ Oil)
46-70272 (Blk)
46-70270 (RAW)

aFe Gear



P/N: 40-30372 (M)
P/N: 40-30373 (L)
P/N: 40-30374 (XL)
P/N: 40-30375 (2XL)

Exhaust System



P/N: 49-42041-B (Blk)
49-42041-P (Pol)

SCORCHER HD Module



P/N: 77-42010

Intercooler w/ Tubes

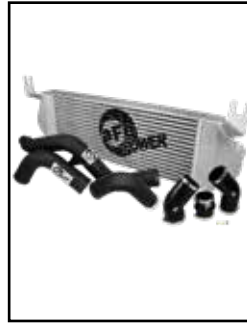

P/N: 46-20172

Engine Oil Pan



P/N: 46-70282 (Blk)
46-70280 (RAW)

Oil Filter

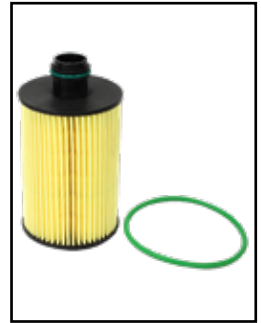

P/N: 44-LF035

Intercooler Tubes



P/N: 46-20174-B (Blk)
46-20174-R (Red)

To purchase any of the items above, view airflow charts, dyno graphs, photos, and video; please go to aFepower.com.

Warranty

General Terms:

- aFe warrants their products to be free from manufacturer's defects due to workmanship and material.
- This warranty applies only to the original purchaser of the product and is non-transferrable.
- Proof of purchase of the aFe product is required for all warranty claims.
- Warranty is valid provided aFe instructions for installation and/or cleaning were properly followed.
- Proper maintenance with regular inspections of product is required to insure warranty coverage.
- Damage due to improper installation, abuse, unauthorized repair or alteration is not warranted.
- Incidental or consequential damages or cost, including installation and removal of part, incurred due to failure of aFe product is not covered under this warranty.
- All warranty is limited to the repair and/or replacement of the aFe part. To request Return Goods Authorization ("RGA"), email RGA@afepower.com or call (951)493-7100. Upon receipt of the RGA, you must return the product to the address provided in the RGA, freight prepaid and accompanied with a dated proof of purchase and the RGA. Upon receipt of the defective product and upon verification of proof of purchase, aFe will either repair or replace the defective product within a reasonable time, not to exceed thirty days.

Product Category	P/N Prefix	Warranty duration
Direct OE Replacement Filters	10, 11, 30, 31, 71, 73	Life of the vehicle
Racing Filters	18	1 year
Universal	21, 24, 72, TF	2 years
Air Intake Systems	50, 51, 54, 55, 75, TR, TA, TL	2 years
Exhaust Systems	49	2 years
Intercoolers & Intercooler Tubes	46-2	2 years
Intake Manifolds	46-1	2 years
Differential Cover	46-7	Life of the vehicle
Exhaust Manifolds	46	2 years
Throttle Body Spacers	46-3	2 years
Turbochargers	46-6	2 years*
Fluid Filters	44	90 days
Pre-Filters	28	2 years
Heavy Duty OE Replacement	70	2 years
PowerSports OE Replacement	81, 87	2 years
PowerSports Intake Systems	85	2 years

No other warranty expressed or implied applies nor is any person or advanced FLOW engineering authorized to assume any other warranty. Some States do not allow the exclusion or limitation of incidental or consequential damages or do not allow limitations on how long an implied warranty lasts, so the above limitations or exclusions may not apply to you. This warranty gives you specific legal rights, and you may also have other rights which vary from State to State.

*See turbocharger warranty for more info



advanced FLOW engineering, inc.

252 Granite Street Corona, CA 92879

TEL: 951.493.7185